



INTERNATIONAL JOURNAL FOR ENGINEERING APPLICATIONS AND TECHNOLOGY

“Automated Seed Sowing Agribotusing Arduino Module”

Prof.Anuprita Linge¹, Miss. Kanchan Wasu², Miss. Rekha Mohare³ Miss. Apurva Masne⁴

¹*Prof., E.N.T.C, S.S.P.A.C.E, Maharashtra, India,anupritalinge@rediffmail.com*

²*Student, E.N.T.C, S.S.P.A.C.E, Maharashtra, India,kanchanwasu620@gmail.com*

³*Student, E.N.T.C, S.S.P.A.C.E, Maharashtra, India,rekhamohare61@gmail.com*

³*Student, E.N.T.C, S.S.P.A.C.E, Maharashtra, India,masne.apurva@gmail.com*

Abstract

Agriculture is the backbone of Indian economy. About half of the total population of our country has chosen agriculture as their chief occupation. The states like Maharashtra, Punjab, and Kerala, Assam are highly involved in agriculture. It all started due to the impact of, “Green Revolution” by means of which farmers came to know about the various techniques involved in farming and the advantages in it. As centuries passed, certain modern techniques were invented in agriculture due to the progress in science. These modern techniques included the use of tractors for ploughing the field, production of pesticides, invention of tube-wells etc. Since water is the main necessity in this scenario, techniques were discovered which would help in watering the field easily, consume less water and reduce human efforts. These discoveries improved the standard of living of farmers. Agro-Technology is the process of applying the technology innovation occurring in daily life and applying that to the agriculture sector which improves the efficiency of the crop produced and also to develop a better Mechanical machine to help the agriculture field which reduces the amount and time of work spent on one crop. Hence in this work of project we decided to design a better mechanical machine which is available to the farmers at a cheaper rate and also which can sow and seed the crop at the same time. This project consists of the better design of the machine which can be used specifically for sowing of soybean, maize, pigeon pea, Bengal gram, groundnut etc. For various agricultural implements and non-availability of sufficient farm labour, various models of seed sowing implements becoming popular in dry land regions of India. The success of crop production depends on timely seeding of these crops with reduced dull work of farm labour. The ultimate objective of seed planting using improve sowing equipment is to achieve precise seed distribution within the row.

Keywords:-NPK, DC, Robot

1. INTRODUCTION

India record of progress in agriculture over the past four decades has been quite impressive. The agriculture sector has been successful in keeping pace with rising demand for food. The contribution of increased land area under agricultural production has declined over time and increases in production in the past two decades have been almost entirely due to increased productivity. Contribution of agricultural growth to overall progress has been widespread. Increased productivity has helped to feed the poor, enhanced farm income and provided opportunities for both direct and indirect employment. The success of India's agriculture is attributed to a series of steps. The major sources of agricultural growth during this period were the spread of modern crop varieties, intensification of input use and investments leading to expansion in the irrigated area. In areas where 'Green Revolution' technologies had major impact, growth has now slowed. New technologies are needed to push out yield frontiers, utilize inputs more efficiently and diversify to more sustainable and higher value cropping patterns". At the same time there is urgency to better exploit potential of rain fed and other less endowed areas. Given the wide range of agro ecological setting and producers, Indian agriculture is faced with a great diversity of needs, opportunities and prospects. Future growth needs to be more rapid, more widely distributed and better targeted. These challenges have profound implications for the way farmers' problems are

conceived, researched and transferred to the farmers. "On the one hand agricultural research will increasingly be required to address location specific problems facing the communities on the other the systems will have to position themselves in an increasingly competitive environment to generate and adopt cutting edge technologies to bear upon the solutions facing a vast majority of resource poor farmers". The robotic systems play an immense role in all sections of societies, organization and industrial units. The objective of the project is to develop a microcontroller based system at helps in on-farm operations like seeding and fertilizing at pre-designated distance and depths with all applicable. Agriculture comes from two Latin words: Ager which means a field. Cultura which means cultivation, Due to traditional methods of agricultural process the Indian farmer faces many problems about productivity of agricultural product than others. It is due to unbalance feeding of fertilizer without knowing the actual requirement of nutrient to a particular crop. Digital models of biological objects have proven to deliver new facilities for the analysis of structural and functional interrelationships as well as developmental processes in a spatial or spatiotemporal context .We are working towards the generation of a generalized 3-D anatomical atlas of developing barley grains at different developmental stages. Serving as reference framework for the integration, visualization, and exploration of various data modalities, such inter-individual atlases significantly promote the analysis of developmental gradients and dynamics.

Traditional methods include broadcasting manually, opening furrows by a country plough and dropping seeds by hand, and dropping seeds in the furrow through a bamboo/meta funnel attached to a country plough . For sowing in small areas dibbling i.e., making holes or slits by a stick or tool and dropping seeds by hand is practiced. Multi row traditional seeding devices with manual metering of seeds are quite popular with experienced farmers In the current generation most of the countries do not have sufficient skilled man power specifically in agricultural sector and it affects the growth of developing countries. So it's a time to automate the sector to overcome this problem. In India there are 70% people dependent on agriculture. So we need to study agriculture. Innovative idea of our project is to automate the process of sowing crops such as sunflower, baby corn, groundnut and vegetables like beans, lady's finger, pumpkin and pulses like black gram, green gram etc& to reduce the human effort and increase the yield. The distance between the two seeds are controlled and varied by using Microcontroller. It is also possible to cultivate different kinds of seeds with different distance. When the Robot reaches the end of the field we can change the direction with the help of remote switches. The whole process is controlled by Microcontroller. Seed plantation is our day to day life is done by tractor in farms. The conventional method for seeding is the manual one. But it requires more time & the man power shortage is faced continuously. India is agrarian economies and most of rural populations depend on agriculture to

earn their livelihood. Agriculture is the largest livelihood provided in India mostly in the rural areas. The farmers are in need of seeds for ploughing& cultivation. The seeds are available in packets & many industries deal in manufacture of such seed packets. In Modern world, Automation robot is used in many of the fields such as defence, surveillance, medical field,industries and so on. The robot system is used to develop the process of cultivating agricultural land without the use of man power. The aim of our project is to reduce the man power, time and increase the productivity rate. All the basic automation robot works like weeding, harvesting and so on. In current generation most of the countries do not have sufficient human factor in agricultural sector and it affects the growth of developing countries so it's time to automate the sector to overcome this problem. All the processes are advance to modifying the mechanism in farming which works automatically without the man power requirement.The small machine would be assembled from existing mass produced components without the need of specialized design and tooling. Also energy require to this machine is less as compared with tractors or any agricultural instrument. Seeding preparation is our day to day life we use tractor in farms. But it requires more time and the man shortage is faced continuously. Now a day soil is tested in laboratory and proper analysis of soil is done and amount of various contains and their ratio are measured but laboratories are normally in district places and it is little bit time consuming process. This proposed

system contributes to give contain of NPK in soil within some minutes. N (Nitrogen) - for growth of leaves and vegetation. P (Phosphorus)-for root and growth. K (Potassium)-regulation of water Nutrient in plant cell, flowering, fruiting, Seeding is one of the main process of farming activity. It also takes more power that can be reduced with this system, seeding is automated which helps linear way of seeding and time consumption is reduced. The NPK value is measured and compared with the standard value for particular crop is known so the difference amount of fertilizer is dispensed by robot.

2. BLOCK DIAGRAM

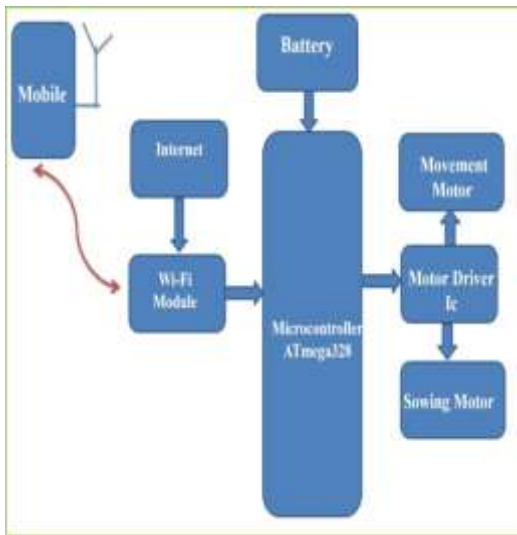

Fig.2 Block Diagram

2.1 Block Diagram Description

Figure 2 shows the block diagram of automated seed sowing machine. It consists of PIC microcontroller, DC motors with driver, LCD, Solenoid valve, relay and its driver. This is an Autonomous agricultural Robot. Here, as soon as the user presses the start button the robot starts

moving in the forward direction. In Microcontroller, we have already programmed the robots working. When the robot starts moving in the forward motion after few distance it stops and then it starts drilling with the help of a drilling mechanism. After this process, there's a Solenoid valve arrangement through which the seeds are being dispensed in the soil. This same procedure continues until the user does not switch off the circuit. Drilling process is done with DC motor and seed dropping in land is done with the help of a two port solenoid valve. All these processes are displayed on LCD.

3. CIRCUIT DIAGRAM

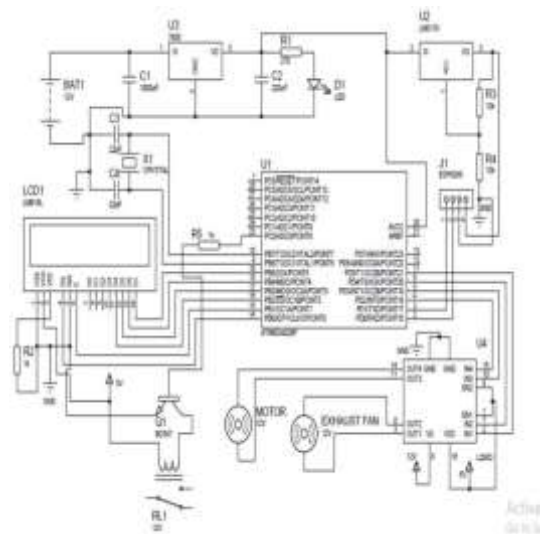

Fig. 3.1 Circuit Diagram

The MAX232 IC is used to convert the TTL/CMOS log-ic levels to RS232 logic levels during serial communication of microcontrollers with PC. The controller operates at TTL logic level (0-5V) whereas the serial communication in PC works on RS232 standards (-25 V to + 25V). This makes it difficult to establish a direct link between them to

com-municate with each other. The intermediate link is provided through MAX232. It is a dual driver/receiver that includes a capacitive voltage generator to supply RS232 voltage levels from a single 5V supply.

The receivers, on the other hand, takes input from trans-mission pin of RS232 serial port and give serial output to microcontroller's receiver pin. MAX232 needs four external capacitors whose value ranges from 1 μ F to 22 μ F.

This part explains how the actual process is being done. The working of the project is explained below as follows:

At the first Stage we should fill the seeds inside the container. Then select the button for distance between the seeds. When the power supply is given to the robo its start to move in the field. The time taken to reach the distance is feed into the microcontroller when it reaches the distance it will stop the robo by OFF the geared motor with the use of relay. establish by remote control.

4. PROJECT DESCRIPTION

4.1 Design and Implementation

In this chapter we are going to discuss in detail various components used in our project. Various features of those components, their ratings, their characteristics and usefulness in project are described in this chapter.

4.2 List of Components

1. Arduino module

2. Motor
3. L293D Driver Circuit
4. Pin Diagram
5. Motor Driver Circuit
6. Battery
7. Blynk Android Application
8. LCD
9. IR Sensor
10. Solenoid Valve
11. Power Supply
12. Keypad

5. APPLICATIONS

5.1 Gardening

Seeds are broadcasted on the soil which results in the loss and damage of the seeds. As the cost of seeds is more and cannot be affordable for the farmers so there is the need for the proper placement of seeds in the soil.

5.2 Sport's Stadium

The fluted roller seed cup is having the arrangement of seed cut-off and controlling flap to control the amount of seeds and fertilizers.

6. ADVANTAGE

6.1 Reduce the manual work

Anyone that has ever had the task of relocating a fixed conveyor system knows that this can be a cumbersome under-taking. Through the use of advanced ASSR technology and wireless routing, vehicles can be quickly reprogrammed to change path or operation, eliminating the need for expensive retrofitting. New directions, tasks, and work cells can be created almost instantaneously

without the need for physical equipment installation.

6.2 Less skill technicians is sufficient to operate.

Through the advancement of control systems ASSRs offer a safe and predictable method of delivery, while avoiding interference with human and building factors. ASSRs can operate almost around the clock, without the need for breaks and vacation time. In addition, ASSRs operate in conditions that may not be suitable for human operators, such as extreme temperatures and hazardous environments.

6.3 Installation is simplified very much

Automated Seed Sowing, combined with RF technology, interface with the Warehouse Control System or Warehouse Management System to improve accuracy and efficiency. ASSRs have little downtime, and operate at a fixed rate to meet a predictable metric for operational activity.

7. CONCLUSION AND FUTURE SCOPE

7.1 Conclusion

The main focus of this system is its Automatic way of sowing the seeds. The seeds are sown in a proper sequence which results in proper germination of seeds. This automatic way of sowing seeds using a robot reduces the labor requirement. Here the wastage of seeds is also reduced to a greater extent. This system has been developed for the sowing of seeds in an automatic way. Here with the help of a robot the seeds are dispensed in the soil in a proper sequence hereby reducing the

wastage of seeds. The planting process of the onion crop only has been implemented by using this Seed Sowing V robot autonomously. This robot will help the farmers to do the farming process efficiently. The project can be enhanced to any other kinds of crop such as fruits, paddy, sugarcane etc. The robot can be designed with chain roller instead of normal wheel. Hence, it can be applicable to the real time agricultural field.

7.2 Future Scope

Introduction of Cutter in place of drill can be used as grass cutter equipment. Using remote control machine can be made automatic. Addition of multi-hopper can be attached side by side for sowing of large farm. Water dripping unit could be included in seed sowing machine. If the system is attached to the solar vehicle this will be very time efficient as well as effortless work will be done by the farmer with automatic, accurate and efficient way.

8. REFERENCE

- [1] Green Growth Management by Using Arm Controller, B Yogesh Ramdas et al Int. Journal of Engineering Research and Applications ISSN : 2248-9622, Vol. 4, Issue 3(Version 1), March 2014, pp.360-363.
- [2] D.S.Suresh, Jyothi Prakash K V, Rajendra C J, "Automated Soil Testing Device", ITSI Transactions on Electrical and Electronics Engineering (ITSI-TEEE) ISSN (PRINT): 2320 – 8945, Volume - 1, Issue -5, 2013.
- [3] "Soil Testing in India", Department of Agriculture & Co-operation, Ministry of Agriculture, Government of India, New Delhi, January, 2011.

- [4]Sneha J. Bansod, Shubhadha Thakre, “Near Infra-red Spectroscopy based Soil Nitrogen measurement”, International Journal of Current Engineering and Technology E-ISSN 2277 – 4106, P-ISSN 2347 – 5161.