



Smart Garbage Monitoring System with Compressing Mechanism

Jyoti Savakare¹, Shubhangi Solunke², Rahul Tagalpallewar³, Mahesh Bhagwat⁴.

1: Student, Department of E&TC, SKN-SITS, Lonavala, Maharashtra, India, savakare1jyoti@gmail.com

2: Student, Department of E&TC, SKN-SITS, Lonavala, Maharashtra, India, solunkeshubhangi88@gmail.com

3: Student, Department of E&TC, SKN-SITS, Lonavala, Maharashtra, India, rahultagalpallewar1234@gmail.com

4: Assistant professor, Department of E&TC, SKN-SITS, Lonavala, Maharashtra, India, mahesh.bhagwat4@gmail.com

Abstract

The aim of this system is to construct innovative system to overcome the problems which is related to the garbage. This system is motivated from normal garbage collection system. Here, we introduced a new mechanism to handle overloaded garbage tank. This mechanism is nothing but the 'compressing mechanism' and the main purpose of this system to monitor garbage and whenever the garbage tank is full it starts its mechanism. This mechanism compresses the garbage and formed sheets. There are various sensors are used to monitor every condition of garbage tank and sheet collection bin. This project is based on the PIC Microcontroller and GPRS Modem. Data which is to be obtained by monitoring garbage tank and sheets collection tank are uploaded to the web server via GPRS Modem. This system specially designed to reduce human efforts and to increase garbage tank capacity in overcrowded area. This system is one of the major applications of 'Internet of Things (IOT)' concept.

KEYWORDS: PIC Microcontroller, IR Sensor, Ultrasonic sensor, GPRS Module, Compressor.

1. INTRODUCTION

Our day to day life is busy because of many things. These things may be personal or professional so, there is no time for to handle or monitor all the things which are related to our surrounding environment. This is main reason for the growth of many unwanted conditions. These conditions may be harmful to us. Such type of one condition is overflow of garbage, this is the main reason of many disease and many type of pollutions which affects on our health as well as on our environment. some metropolitans cities are overcrowded. As compare growing area man power is less so it is not able to monitor all garbage tank which are available in specific area. By this mechanism, all the managing and controlling of garbage is done automatically.[1]

In this project IOT Garbage Monitoring system is a very innovative system which will help to keep the cities clean. This system monitors the garbage bins and informs about the level of garbage collected in the garbage bins via a web page. The web page gives a graphical view of the garbage bins and highlights the garbage collected in color in order to show the level of garbage collected. IR sensors and ultrasonic sensors

are also helpful for this system. The IR Sensor-Single is a general purpose proximity sensor. Here, we use it for collision detection. The module consists of a IR emitter and IR receiver pair. The high precision IR receiver always detects a IR signal. Ultrasonic ranging module provides 2cm - 400cm non-contact measurement function, the ranging accuracy can reach to 3mm. The modules include ultrasonic transmitters, receiver and control circuit.

2. LITERATURE REVIEW

This idea is motivated from the systems which are already used in Municipal Corporation. This project implements the little bit new idea, mechanism to improve system work and efficiency. The following table gives the overview of others system which are similar to this system table no. various papers used different mechanism to implement garbage tank. For this purpose no of processors and communication devices used according to the specifications and applications. Table-1 gives total information of others systems and how these systems are different than proposed system. Proposed system

is inspired by these another system. Some system has many drawbacks, by implementing this system some drawbacks can be minimized and system accuracy can be increased. System became more reliable due to the use of various types of sensors.

Table-1: Literature review

Sr. No.	Title of Ref. paper	Technology used	Work done	Remark
1	IOT Based waste management for smart city. (Parkash.PG Diploma Student, Dept. of Embedded System Design, NIELIT, Calicut, Kerala, India) (Prabhu V. IPG Diploma Student, Dept. of Embedded System Design, NIELIT, Calicut, Kerala, India)	Arduino Software is used with the help of Microcontroller 8051. And ARM7 is also used.	In this system Zigbee, ARM 7 and GSM is used to monitor garbage tank continuously. Sensors are placed at the neat position on garbage tank, when sensor sense garbage level it provides information to the ARM 7.	Data can be detected wirelessly, sensor always monitor the level of garbage.
2	Smart Dustbin-An Efficient Garbage Monitoring System (Monika K A, NikithaRao, Prapulla S B, ShobhaG. Department Comp. Science and Engg.R V College of Engineering, India)	GSM 900 is used . Minimal no smart bins is used instead of no of plenty dustbin placed in improper fashion.	GSM 900 is used for sending message purpose. For standard communication purpose GSM/GPRS is used and for interfacing MAX 232 is used.	No of advantages can be obtained such as durability, affordability etc. only using a smart bins.
3	IOTBased Intelligent Bin for Smart Cities (Meghana K C, Dept of Electronics & Comm. Engg.S. J. B Institute of Technology Bengaluru, India) (Dr. K R Nataraj Dept of E&tcEngineering S. J.B Institute of Tech. Bengaluru, India)	For the communication purpose GSM, zigbee module is used. ARM dual core processor is used for monitor purpose and various sensors are used like IR Sensor.	This system provides total guidance of garbage management system, and takes preventive action when garbage tank is completely filled.	This paper gives the solution related to the time and garbage vehicles management.
4	IoT Based Smart Garbage and Waste Collection Bin S.S.Navghane, M.S.Killedar. (SKN-SITS, Dept. of E&T,C, Lonavala) Dr. V.M.Rohokale (Asst. Professor, SKN-SITS, Lonavala)	LPC2148 and IR sensor is used. Weight sensor is also is used. For communication purpose Wi-Fi module is used.	IR sensor and Weight sensor sense the position of garbage bins. And controlling action send to the Microcontroller (LPC2148). An then microcontroller send the information to the Wi-Fi	This system avoids the corruption due to the use of weight sensor. Reduce expenditure value regarding to the garbage vehicles.

			module.	
5	A Smart Waste Management with Self-Describingobjects (YannGlouche,PaulCouderc,INRIA, UniteRecherche Rennes-Bretagne-Atlantique Campus de Beaulieu, Rennes, Franc)	RFID is used.	Here QR code is given to the any physical waste and the address of QR code is stored in RFID tag memory.	This system avoid the additional time related to waste management and gives sufficient waste management system result

3. BLOCK DIAGRAM

This system is basically based on PIC16F877A Microcontroller. The input from various sensors goes to the microcontroller and output of microcontroller is given to the GPRS module and Compressor. The actual block diagram of system shown in fig.1

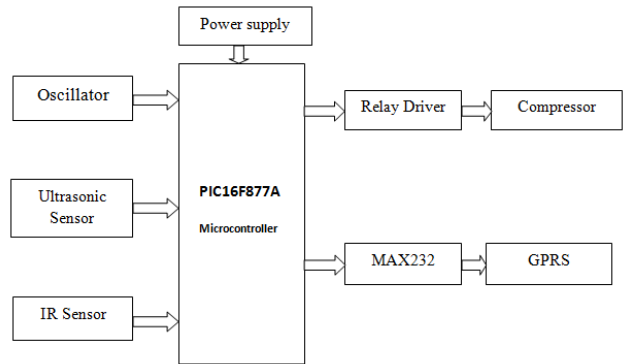

Fig-1: Block diagram of SGMS

4. PROPOSED SYSTEM

A. Methodology

This system is basically depending on PIC Microcontroller, GPRS Model. The connection between them is can be done with the help of MAX 232.

Hardware requirement is, PIC Microcontroller, DC Motor, IR Sensor, Ultrasonic Sensor, GPRS Module, Regulator IC.

Software requirement for the system is Orcade software, MPLAB IDE Software.

i. PIC Microcontroller

The PIC16F876/873 devices come in 28-pin packages and the PIC16F877/874 devices come in 40-pin packages. The Parallel Slave Port is not implemented on the 28-pin devices. There are three memory blocks in each of the PIC16F87X MCUs. The Program Memory and Data Memory have separate buses so that concurrent access can occur and is detailed in this section. The PIC16F87X devices have a 13-bit program counter capable of addressing an 8K x 14 program memory space. The PIC16F877/876 devices have 8K x 14 words of FLASH program memory, and the PIC16F873/874 devices have 4K x 14. Accessing a location above the physically implemented address will cause a wraparound. The RESET vector is at 0000h and the interrupt vector is at 0004h.

ii. IR Sensor

The IR Sensor is a general purpose sensor. Here we use this IR sensor for collision detection. The IR Sensor module consists pair of a IR emitter and IR receiver. The high precision IR receiver always detects a IR signal. The module contains LM324 comparator IC for the comparison of threshold value and output value. The output of sensor is high whenever it IR frequency and low otherwise. The on-board LED indicator helps user to check status of the sensor without using any additional hardware. Power consumption of this pair is comparatively low and output of this pair is can be obtain in digital form. Following table no.1 shows the pin configuration of IR sensor.

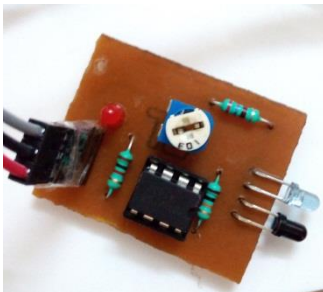

Fig-2: IR sensor

Table-2: Pin configuration of IR Sensor

Pin No .	Connection	Description
1	Output	Digital output (High or Low)
2	VCC	Connected to circuit supply
3	Ground	Connected to circuit ground

iii. Ultrasonic sensor

This ultrasonic sensor module consists of transmitters, receiver and control circuit. Range of this module is 2cm - 400cm non-contact measurement function, the accuracy of

ranging can reach to 3mm. The basic working principle of ultrasonic sensor is, by using IO trigger gives minimum 10us high level signal to receiver of sensor and then transmitter of this module automatically send 840 kHz signal and detect the pulse signal back.



Fig-3: Ultrasonic sensor

iv. GPRS Module

GPRS module is same as general GPRS Modem, but between of those there is main difference, A GPRS Modem is can be external equipment, whereas the GPRS Module is a module that can be integrated within equipment. It can be embedded part of any equipment. As GSM modem is a wireless modem hence it works with GSM networks. A Hayes modem sends and receives data through a fixed telephone line while a GSM modem sends and receives data through radio waves that is main difference between this modems.



Fig-4: GPRS module

v. Compre

Air compressor it converts power in to the potential energy which is stored in pressurized air form. Compressor use stop button to stop motor when pressure reaches to its upper level. From the fig-5 two cylinders are used one for forward and backward movement and another is for upward and downward movement. By using tee both cylinders are connected to air compressor. Electric valve are also for to connect compressor tubes to cylinder. Upward and downward cylinder compressed the garbage and forward and backward cylinder move the formed sheet in to sheet collection been.

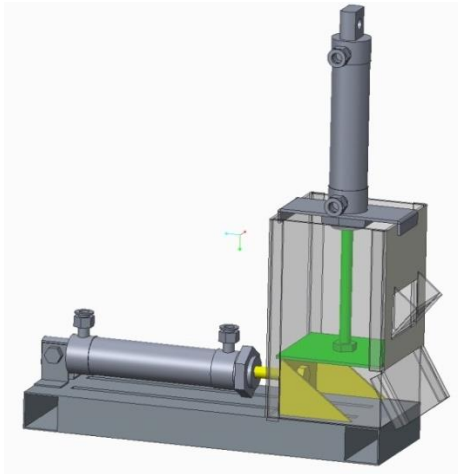

Fig-5: Compressor

For to compressed garbage 2 to 8 bar pressure is required. It will be changes regarding to garbage quantity and condition. Here, 5*2 electric valves is used to control, monitor the pressure which is comes from air compressor.

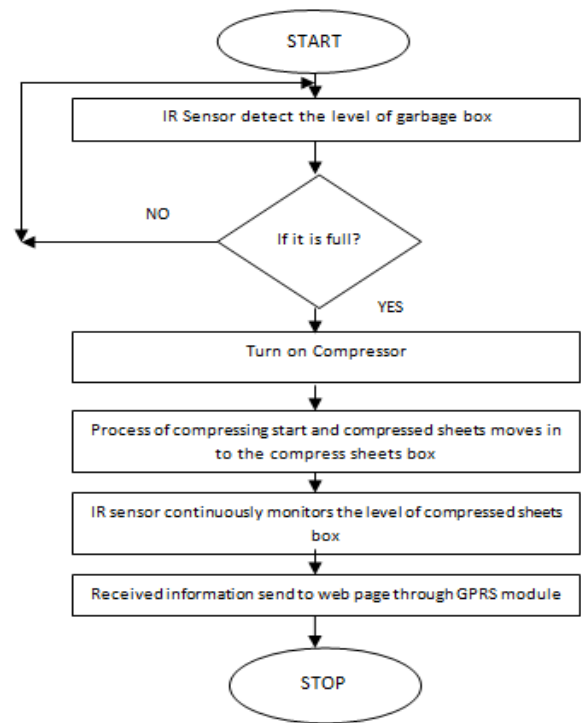

Fig-6: Flowchart of SGMS

5. FLOWCHART and ALGORITHM

Algorithm

- 1: Start
- 2: Initialize the system.
- 3: Use the ultrasonic sensor to know the level of garbage in garbage box.
- 4: If it's full using compressing mechanism compress the garbage & form sheets.
- 5: Check the level of sheets using IR sensor.
- 6: Send the data level to the web source using GPRS module.
- 7: Stop.

Flowchart

6. RESULT

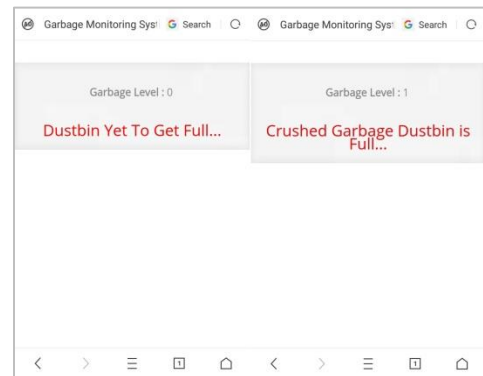

Fig-7: Webpage result of SGMS system

Fig-7 shows the result of sheet collection when sensed by the IR sensor. From the fig, when collection is not full then it shows the level as 0 while it gets full it displays the result as 1. The sensed level can be updated after 3 seconds automatically.

7. CONCLUSION

By implementing this system, the cost will be reduced. Resource optimization can be done. This system is useful for increasing the capacity of the garbage tank by using a compressing method.

8. REFERENCES

- [1] Prakash, Prabhu," IOT Based Waste Management For Smart Cities", International Journal Innovative Research In Computer And Communication Engineering,Vol.4, Issue 2, February-2016[pp1267-1274].
- [2]S.S.Navghane, M.S. Killedar, Dr. V.M.Rohokale,"IOT Based Smart Garbage And Waste Collection Bin", International Journal Of Advanced Research In Electronic And Telecommunication Engineering (IJARECE),ISSN:2278-909X, Vol.5,Issue 5,May-2016,[pp 1576-1578].
- [3] Insung Hong, Sunghoi Park, Beomseok Lee, Jaekeun Lee, Daebeom Jeong,And Sehyun Park,"IOT Based Smart Garbage System For Efficient Food waste management",Hindawi Publishing Corporation The Scientific World journal, Vol.2014,Article ID 646953,[pp 13 pages].
- [4] Meghana K.C., Dr. K.R. Nataraj,"IOT Based Intelligent Bin for Smart Cities",International Journal On Recent And Innovative Trends In Computing And Communications, Vol.4,Issue:5,ISSN:2321-8169,[pp 225-229].
- [5] Yann Glouche, Paul Coudere,"A Smart waste Management With Self- Describing Objects",The Second Internation Conference On Smart System, Devices And Technology(SMART'13),Jun 2013,Rome, Italy.2013<hal-00924270>.
- [6] Senthil Kannan.N,Naveen Prasad.D,Nirmal Kumar.R,Premvishnu.R.S,"Design Of Mechanical Crushing Machine", International Research Journal Of Engineering And Technology(IRJET),Vol.3,Issue:01|Jan-2016,e-ISSN:2395-0056,p-ISSN:2395-0072,[pp 921-926].
- [7] Narayan Sharma, Nirman Singha, Tanmoy Dutta, "Smart Bin Implementation for Smart Cities",International Journal of Scientific & Engineering Research, vol 6, Issue 9, 2015,pp-787-789.
- [8] Raghmani Singh, C. Dey, M. Solid waste management of Thoubal Municipality, Manipur-a case study Green Technology andEnvironmental Conservation (GTEC 2011), 2011 International Conference Chennai 21–24.
- [9]K. Vidyasagar, M. Sumalatha, K. Swathi and M. Rambabu,"Eco-friendly Environment with RFID Communication Imparted Waste Collecting Robot", Journal of Academia and Industrial Research (JAIR) Volume 4, Issue 2 July2015,pp.43-47.
- [10] Twinkle Sinha, Mugesh Kumar, P.Saisharan,"Smart Dustbin", International Journal of Industrial Electronics and Electrical Engineering, SRM University, India, vol-3, Issue-5, 2015,pp.101-104.
- [11] Vikrant Bhor, "Smart Garbage management System International Journal of Engineering Research & Technology (IJERT), Vol. 4 Issue 03, March-20152000.
- [12] Insung Hong,Sunghoi Park,Beomseok Lee,Jaekeun Lee,Daebeom Jeong,and Sehyun Park, "IoT-Based Smart Garbage System for Efficient Food Waste Management", The Scientific World Journal Volume2014(2014), Article ID646953.

