



# Design and Implementation of Smart Hydroponic Monitoring & Controlling System

GAURAV KUMAR<sup>1</sup>, KRITESH KUMAR<sup>2</sup>, MAYANK MISHRA<sup>3</sup>, PRIYANKA HALLE<sup>4</sup>

<sup>1</sup>BE , E&TC, SKNSITS, Lonavala , Maharashtra, India, [gauravkumar95190@gmail.com](mailto:gauravkumar95190@gmail.com)

<sup>2</sup>BE , E&TC, SKNSITS, Lonavala , Maharashtra, India, [kritesh32@gmail.com](mailto:kritesh32@gmail.com)

<sup>3</sup>BE , E&TC, SKNSITS, Lonavala , Maharashtra, India, [mayankmshr36@gmail.com](mailto:mayankmshr36@gmail.com)

<sup>4</sup> Asst.Professor Department Of E&TC, SKNSIT Maharashtra India, [hallepriyanka2011@gmail.com](mailto:hallepriyanka2011@gmail.com)

## Abstract

The term "Hydroponics" is derived from two Greek words i.e. "pones" which means working & "Hydro" means water that started to be used in 1950. The main objective of the project is to design a Smart monitoring and Controlling system is that it is eco friendly and doesn't affect the environment. This system consists of mainly three parts i.e. Data Acquisition, Mobile Transfer and for Intelligence applications with the help of microcontrollers. Actually some sensors are used to analyze the conditions of the atmosphere and helps in man-machine interaction. Meanwhile with the help of mobile we can also control smart hydroponic system simultaneously with the help of Wi-Fi module or GSM module to get the current update. Hence this system helps in huge encouragement to the smart hydroponic system.

**Index Terms:** Hydroponics, LM 35 Sensor, HS(Humidity Sensor), Wi-Fi Module, etc.

\*\*\*

## 1. INTRODUCTION

The increase in massive industrialization and decrease in the area of vegetation or lack of area leads to the emergence of hydroponic system. Also in other words due to infertility of the land i.e. the land not suitable to grow crops leads to the emergence of hydroponic system say the example of deserts. Hence systems helps to monitor and control the unconditional environment which helps in the growth of crop in a proper way and leads to good production of crops within a limited area also fresh variety of crops which are also in healthy condition to eat and to grow by providing certain environmental conditions which are necessary for the growth of plants and also monitors the growth and provides the update to the users. This system helps to monitor everything automatically without the interaction or interference of human being and with the help of so that surveillance & monitoring the region or area can be done in a proper manner and the whole system is worthwhile. Hydroponic system is useful for growing and monitoring such type of plant which are soilless means. This is a method of growing crops in water with the help of nutrients by mixing with water.

This paper shows the implementation of Hydroponic monitoring and controlling system with the help of Microcontrollers, Sensors (humidity & temp. sensor), motor, pump etc. Hence it is

one of the best methods to keep surveillance and monitor the growth rate.

The main advantages are

- Reduces the use of fertilizer.
- Reduces man power.
- Production rate is high
- Faster the plant growth rate.
- Improves the quality of output

The main disadvantages are

- It requires constant supervision.
- Technical Knowledge is required to grow plants using hydroponics.
- Water based microorganisms can easily be introduced.

## 2. BLOCK DIAGRAM & ITS DESCRIPTION

In this work, some of the primary objectives are to regulate the nutrient solution according to plant need which enable to reduce

ce a unnecessary use of fertilizer and make the system affordable because as mentioned above high cost of a system is one of the big problem in hydroponics so there is need such kind of system which can control the operation, improve performance and give the desire output at lower cost. There are certain electronic components such as capacitors, diodes, transistors, etc which also plays a vital role in the proper functioning of the model. In this project Wi-Fi module plays a vital role for providing us with the current updates such as update regarding temperature, humidity, etc.

weather conditioning, environmental monitoring, telecom and consumer audio/video applications

### 3. COMPONENT & DESCRIPTION

#### 3.1 Humidity Sensor(SY-HS-220)

A humidity sensor (or hygrometer) senses, measures and reports the relative humidity in the air. It therefore measures both moisture and air temperature. Relative humidity is the ratio of actual moisture in the air to the highest amount of moisture that can be held at that air temperature. The warmer the air temperature is, the more moisture it can hold. Humidity / dew sensors use capacitive measurement, which relies on electrical capacitance. Electrical capacity is the ability of two nearby electrical conductors to create an electrical field between them. The sensor is composed of two metal plates and contains a non-conductive polymer film between them. This film collects moisture from the air, which causes the voltage between the two plates to change. These voltage changes are converted into digital readings showing the level of moisture in the air.



Fig No. 3 Humidity Sensor

#### 3.2 Temperature Sensor (LM 35)

The LM35 series are accuracy integrated-circuit temperature sensor, whose voltage is linearly proportional to the Celsius temperature. The advantage of LM35 over linear temperature sensors calibrated in ° Kelvin, as the user is not required to subtract a large constant voltage from its output to obtain convenient Centigrade scaling. The LM 35 provide typical accuracies of  $\pm 1/4^\circ\text{C}$  at room temperature and  $\pm 3/4^\circ\text{C}$  over a full  $-55$  to  $+150^\circ$  temperature range. It is low cost is assured by timing at the wafer level. The LM35 is low output impedance, linear output and precise inherent calibration make interfacing to read out or control circuitry especially easy. It can be used with single power.

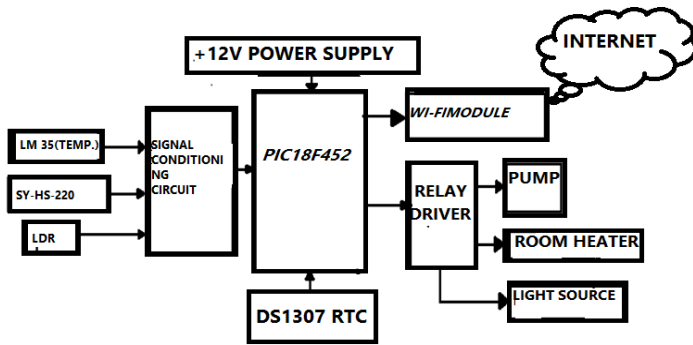

Fig No. 1 Block Diagram

### 2.1 PIC18F452 MICROCONTROLLERS

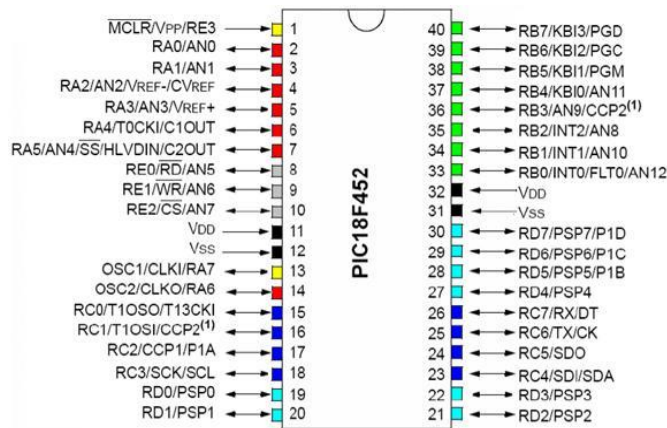

Fig No. 2 PIC 18F452 MICROCONTROLLERS

The PIC18F452 features a 'C' compiler friendly development environment, 256 bytes of EEPROM, Self-programming, an IC D, 2 capture/compare/PWM functions, 8 channels of 10-bit Analog-to-Digital (A/D) converter, the synchronous serial port can be configured as either 3-wire Serial Peripheral Interface (SPI™) or the 2-wire Inter-Integrated Circuit (I<sup>2</sup>C™) bus and Addressable Universal Asynchronous Receiver Transmitter (UART). All of these features make it ideal for manufacturing equipment, instrumentation and monitoring, data acquisition, po

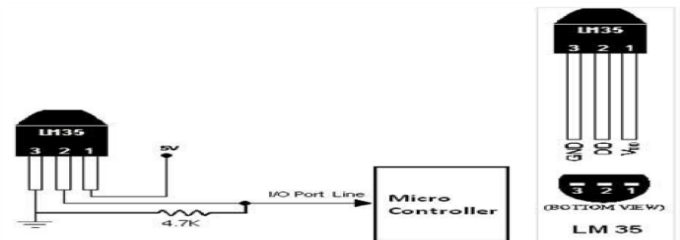

Fig No. 4 Temp Sensor

### 3.3 LDR

A photo resistor (or light-dependent resistor, LDR, or photocell) is a light-controlled variable resistor. The resistance of a photo resistor decreases with increasing incident light intensity; in other words, it exhibits photoconductivity.



Fig No. 5 LDR

### 3.4 WI-FI Module

Wi-Fi module is a self contained SOC with integrated TCP-IP protocol stack that can give any microcontroller access to your Wi-Fi network. The module comes preprogrammed with an AT command set firmware, meaning, you can simply hook this up to your device and get about as much Wi-Fi ability as a Wi-Fi Shield offers (and that's just out of the box)! The module has powerful enough on board processing

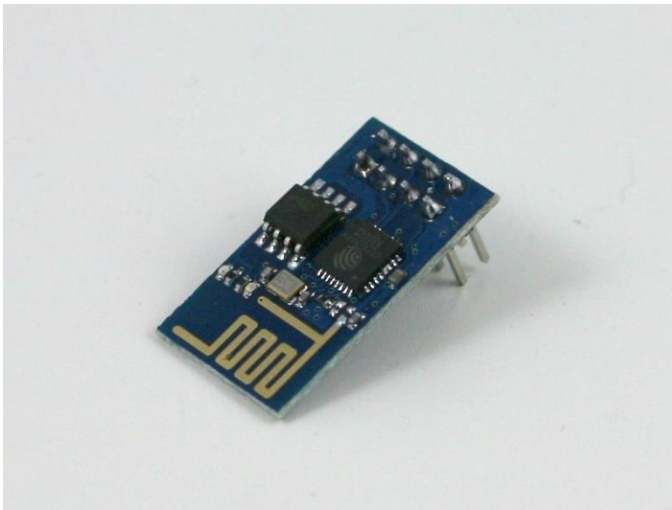

Fig No. 6 WI-FI Module

### 3.5 Display Unit

LCD (Liquid Crystal Display) screen is an electronic display module and find a wide range of applications. A 16x2 LCD display is very basic module and is very commonly used in various devices and circuits. These modules are preferred

over seven segments and other multi segment LEDs. The reasons being: LCDs are economical; easily programmable; have no limitation of displaying special & even custom characters (unlike in seven segments), animations and so on. A **16x2 LCD** means it can display 16 characters per line and there are 2 such lines. In this LCD each character is displayed in 5x7 pixel matrix.

This LCD has two registers, namely, Command and Data. The command register stores the command instructions given to the LCD. A command is an instruction given to LCD to do a predefined task like initializing it, clearing its screen, setting the cursor position, controlling display etc. The data register stores the data to be displayed on the LCD. The data is the ASCII value of the character to be displayed on the LCD.

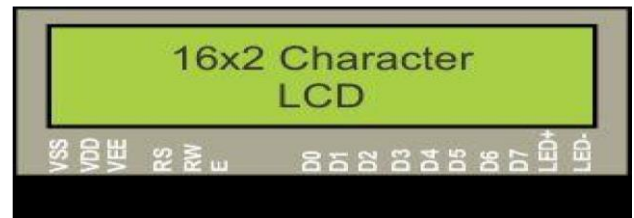

Fig No. 7 Display

### 3.6 ACTUATOR

An actuator is a component of a machine that is responsible for moving or controlling a mechanism or system. An actuator requires a control signal and a source of energy. The control signal is relatively low energy and may be electric voltage or current, pneumatic or hydraulic pressure, or even human power. The supplied main energy source may be electric current, hydraulic fluid pressure, or pneumatic pressure. When the control signal is received, the actuator responds by converting the energy into mechanical motion. An actuator is the mechanism by which a control system acts upon an environment. The control system can be simple (a fixed mechanical or electronic system), software-based (e.g. a printer driver, robot control system), a human, or any other input.

Some features of actuator are: -

- 3.5 -12v D.C input voltage
- Power Range:-0.5 -5 watt
- Submersible pump
- Water output hole:-8mm.



Fig: – Actuator

#### 4. CONCLUSION

This study designs a smart monitoring and control system for aquaponics based on Open Wrt, which is intelligent, accurate and real time and can release the users from the hard working conditions. As one of typical applications, more and more people realize the application of the IoT (Internet of Things) will bring broad development to the smart life. Meanwhile, we have an idea that the device of aquaponics can be connected with social communication platform, which can realize a wonderful, dream that people can interact with their hydroponic plants on line through a mobile terminal.

#### 5. FUTURE SCOPE

The Hydroponic farming can have a great future in India if its value is known and understood to the people. Hydroponic is a method of growing plants using mineral nutrients solutions in water without soil.

The future of Hydroponic system is bright as day by day the cultivation area is decreasing because industrial area is increasing and even due to soil erosion there is less productivity of crops. Hence it increases the rate of productivity and provides better quality of output.

#### REFERENCES

1. Love D C, Fry J P, Genello L, et al. An international survey of Aquaponics Practitioners [J]. Plos One, 2014, 9: e102662.
2. Fitter A H. The topology and geometry of plant root systems: influence of watering rate on root system

topology in *Trifolium pratense*. *Annals of Botany*, 1986, 58(1): 91-101.

3. Chen F, He H, Tang Y. In-situ optimal control of nutrient solution for soilless cultivation [C]. International Conference on Proceedings of the Advanced Computer Control (ICACC), 2011, 412-416.

4. Shafahi M, Woolston D. Aquaponics: A sustainable food production system [C]. ASME 2014 International Mechanical Engineering Congress and Exposition, 2014, V003T03A073.

5. Youquan Huang. Control system design is engaged in pisciculture to the intellect [J]. *Development & Innovation of Machinery & Electrical Products*, 2004, 2: 89-90.

6. Zhai Yanni, Chen Xiaodong. Design of smart home remote monitoring system based on embedded system [C]. IEEE International Conference on Computing, Control and Industrial Engineering (CCIE), 2011, 41-44.

7. Pande, A.B.; Sheikh, N.S.; Upare, K.; Raut, S.; Ali, S. Wireless Sensor Network Based Greenhouse Monitoring System. *Int. J. Res.* 2016, 3, 351-353. 8. Emami, L.; Gonzalez-de-Soto, M.; Pajares, G.; Gonzalez-de-Santos, P. Integrating sensory/actuation systems in agricultural vehicles. *Sensors* 2014, 14, 4014-4049.