



## IOT BASED SMART METER

<sup>1</sup>Anurag Kumar Pandey, <sup>2</sup>Vikash Kumar Choubey, <sup>3</sup>Nirmal Chandra Kunal, <sup>4</sup>Prof. Ankit Chourasia

<sup>1</sup>BE Electrical, Dept. of Electrical Engineering, SKNSITS, Lonavala, Maharashtra, India, [anuragp303@gmail.com](mailto:anuragp303@gmail.com)

<sup>2</sup>BE Electrical, Dept. of Electrical Engineering, SKNSITS, Lonavala, Maharashtra, India, [choubeyvikash589@gmail.com](mailto:choubeyvikash589@gmail.com)

<sup>3</sup>BE Electrical, Dept. of Electrical Engineering, SKNSITS, Lonavala, Maharashtra, India, [nckunal@gmail.com](mailto:nckunal@gmail.com)

<sup>4</sup>Assistant Professor, Dept. of Electrical Engineering, SKNSITS, Lonavala, Maharashtra, India, [chourasiaa.sknsits@sinhgad.edu](mailto:chourasiaa.sknsits@sinhgad.edu)

## Abstract

This project is based on IOT based smart meter. It include hardware like PIC18F452, Relay SPDT, RFID reader, BC547, LCD (16x2), LM7805 Voltage Regulator, Wi-Fi Modem. This project describes billing process of electricity consumption which we are using at present is very long process and require lots of man power. For overcoming all difficulties in existing system we are introducing fully automated billing process. Proposed system will be user friendly and can be operated easily. The Buyer needs to pay for the usage of electricity on schedule, in case that he couldn't pay, the electricity transmission can be turned off autonomously from the distant server. The user can monitor the energy consumption in units from a web page by providing device's IP address. Theft detection unit connected to energy meter will notify company side when meter tampering occurs in energy meter. Wi-Fi unit performs the IOT operation by sending energy meter data to web page which can be accessed through IP address. Bill can be paid by using RFID reader.

*Index Terms:* PIC18F452, wifi, RFID reader, Theft Detection, IOT etc.

\*\*\*

## 1. WHAT IS IOT?

The Internet of things (IoT) is the inter-networking of physical devices, vehicles (also referred to as "connected devices" and "smart devices") buildings, and other items embedded with electronics, software, sensors, actuators, and network connectivity that enable these objects to collect and exchange data. In 2013 the Global Standards Initiative on Internet of Things (IoT-GSI) defined the IoT as "the infrastructure of the information society." The IoT allows objects to be sensed or controlled remotely across existing network infrastructure, creating opportunities for more direct integration of the physical world into computer-based systems, and resulting in improved efficiency, accuracy and economic benefit in addition to reduced human intervention. When IoT is augmented with sensors and actuators, the technology becomes an instance of the more general class of cyber-physical systems, which also encompasses technologies such as smart grids, smart homes, intelligent transportation and smart cities. Each thing is uniquely identifiable through its embedded computing system but is able to interoperate within the existing Internet infrastructure. Experts estimate that the IoT will consist of almost 50 billion objects by 2020.

Typically, IoT is expected to offer advanced connectivity of devices, systems, and services that goes beyond machine-to-machine (M2M) communications and covers a variety of protocols, domains, and applications. The interconnection of

these embedded devices (including smart objects), is expected to usher in automation in nearly all fields, while also enabling advanced applications like a smart grid, and expanding to areas such as smart cities. "Things," in the IoT sense, can refer to a wide variety of devices such as heart monitoring implants, biochip transponders on farm animals, electric clams in coastal waters, automobiles with built-in sensors, DNA analysis devices for environmental/food/pathogen monitoring or field operation devices that assist firefighters in search and rescue operations. Legal scholars suggest looking at "Things" as an "inextricable mixture of hardware, software, data and service" These devices collect useful data with the help of various existing technologies and then autonomously flow the data between other devices. Current market examples include home automation (also known as smart home devices) such as the control and automation of lighting, heating (like smart thermostat), ventilation, air conditioning (HVAC) systems, and appliances such as washer/dryers, robotic vacuums, air purifiers, ovens or refrigerators/freezers that use Wi-Fi for remote monitoring.

## 2. INTRODUCTION

From many years, the electric power systems had undergone negligible changes in their operating conditions and the equipment employed for their control and monitoring. Many attempts have been made to design the energy meter with instant billing but till now the designed energy meters did not

give any replacement for the system where the user has to connect the recharge card to recharging unit, and then the units will be loaded into recharge card. In this proposed work we are implementing a prepaid electricity meter connected to electricity office interface through WiFi network. When we use the electricity the amount which we had used is calculated by energy meter at user interface. This information is passed to microcontroller. Here we use pic18f452 microcontroller programmed with embedded C language. This controller decodes the information given by the electric meter and transmits the information to the server.

Electricity theft has emerged as a serious problem in power sectors especially in the developing countries. A huge amount of revenue is lost due to electricity theft. In some countries this is so severe that governments are incurring losses instead of revenue. In some cases government has to provide subsidies to the power sector to maintain a reasonable price of electricity. The financial loss results in shortage of funds for investments to expand the existing power capacity and as a result governments are failing to satisfy the ever increasing demand of electricity. In some cases this problem has become so extreme that the affected power systems are near bankrupt. Power theft is a concerned issue even in the most efficient power systems.

### 3. RELATED WORK

In this project we are going to make a iot based smart meter by using pic18f452 microcontroller. We are using RFID reader and RFID tag for recharge purpose. The blinking of meter Led is counting through LDR unit. This LDR sense the blinking of meter and give the signal to microcontroller. Also we are using theft detection unit for protecting meter bypass or meter tampering. For theft detection we are using IR sencer.

For transmitting the data or two way communication we are using WiFi. This WiFi will transmit the data to the surver. IoT based meter can improve the efficiency of power system and can help to analyse the unnecessary loss of power in different areas.

#### 3.1 Existing System

The present system only provides feedback to the customer at the end of the month that how much power is consumed in the form of bill. The consumer has no way to track their energy usage on a more immediate basis. The consumers are growing exponentially fast and load on power providing divisions is rapidly rising. In the existing system meter tampering can be done easily and it's one of the major drawbacks for an energy crisis.

#### 3.2 Problem Statement

- Use of electricity is increasing in many-folds day by day and hence it becomes a tough task in handling and maintaining the power as per the requirements.
- Human operator has to visit the customer's house for the billing purpose and has to revisit if the customers are not available in his first trip and hence the billing procedure gets delay.
- Human error while calculating complex electricity bills.

- It is pretty difficult to go to the remote area for the meter reading.
- If the customer does not pay the bill, the operator has to visit the house again to cut-off the supply. Also there will be huge revenue loss to the utilities if the customers do not pay the bills.
- Energy Meter display clarity problem.
- Customers have to stand in queues to pay the bill.

## 4. PROPOSED SYSTEM

In the proposed system, consumer can do power management by knowing energy usage time to time. The Customer needs to pay the bill on schedule, if couldn't, the electric power connectivity can be turned off autonomously from the distant host. RFID reader is used with meter at consumer side, for recharge RFID tag is used. The blinking of meter Led is counting through LDR unit. This LDR sense the blinking of meter and give the signal to microcontroller.

### 4.1 Advantages

The users can be aware of their electricity consumption. The human work of collecting readings by visiting every home at the end of every month can be avoided by generating Electricity bills automatically. Theft of electricity can be avoided by tamper proof energy meters. The errors in the system can be identified quickly

- Ease of accessing information for consumer from energy meter through IoT.
- Theft detection at consumer end in real time.
- LCD displays energy consumption units.
- Disconnection of service from remote server.

## 5. SYSTEM IMPLEMENTATION

The proposed IOT based Energy meter and theft detection using PIC18F452 AND Wi-Fi is implemented at two ends, one on the consumer end for IOT operation and other on the service provider end for observing energy thefts. Theft detection unit connected to energy meter will notify company side when meter tampering and theft detection occurs in energy meter through PLC modem and theft detected will be displayed on the terminal window.

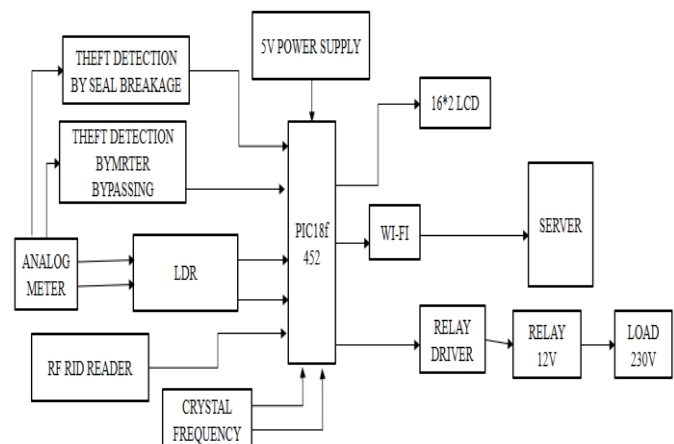
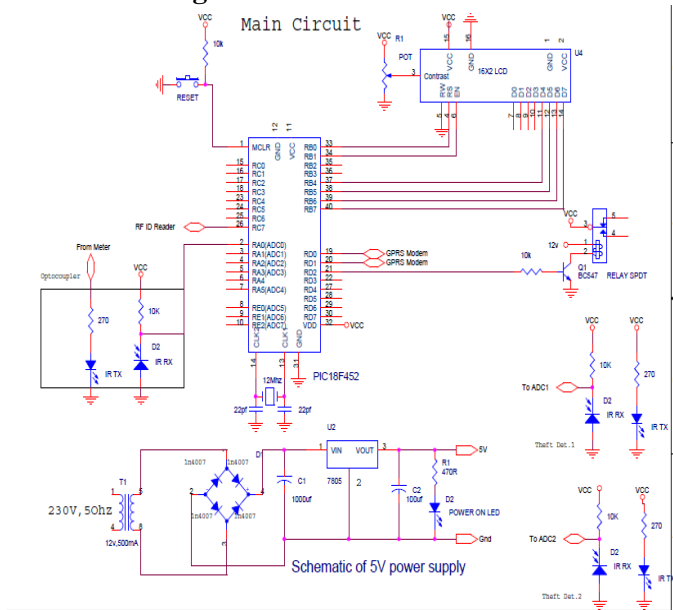

Fig-1: Block diagram

### 5.1 Circuit Diagram



the power source whenever the customer does not pay the monthly bill and also it eliminates the human involvement, delivers effective meter reading, prevent the billing mistake. The Project has achieved following objectives: -

- Theft detection at consumer end in real time.
- LCD displays energy consumption units.
- Disconnection of service from remote server.

### REFERENCES

- [1]. International Journal of Advanced Research in Electrical, Electronics and Instrumentation Engineering (An ISO 3297: 2007 Certified Organization) Vol. 4, Issue 7, July 2015
- [2]. International Research Journal of Engineering and Technology (IRJET) e-ISSN: 2395 -0056 Volume: 03 Issue: 04 | Apr-2016 www.irjet.net p-ISSN: 2395-0072
- [3]. [https://en.wikipedia.org/wiki/Internet\\_of\\_things](https://en.wikipedia.org/wiki/Internet_of_things)

### 6. CONCLUSION

In the era of smart city advancement, this project is concentrated on the connectivity & networking factor of the IoT .In this project, an energy consumption calculation based on the counting of calibration pulses is designed and implemented using PIC18F452. In the proposed work, IoT based meter reading system is designed to continuously monitor the meter reading and service provider can disconnect