



INTERNATIONAL JOURNAL FOR ENGINEERING APPLICATIONS AND TECHNOLOGY

Brake Bias Bar & FEA Analysis

Akshay Bankar, Ankit Bobade, Gaurang Deshmukh

Student, Department of Mechanical Engineering, Jawaharlal Darda College of Engineering & Technology
akshaybankar111@gmail.com

Abstract

Brake Bias Indicated as a share. This means the relative quantity of brake pressure applied from the master cylinder(s) to the front brakes. This can be associate adjustment of the relative quantity of hydraulic pressure applied to the front verses the rear brake callipers and pads. This can be required to optimize the braking power, as an automotive decelerates, load transfers to the front tyres that usually improves their grip, whereas decreasing the grip at the rear of the automotive. During this paper varied levelling of brakes in coach trade are going to be studied and there performance are going to be monitored. The paper is aimed to know that brakes bias and its influence on the automotive performance. The aim of this analysis is to research attainable benefits of active brake pressure management. By estimating the friction ability of the tyres as an operate of measurable vehicle conditions, brake pressure will be applied in proportions acceptable for this dynamic state of the vehicle. The results inflated braking ability before the onset of tire lockup. Stopping distances area unit improved for all braking things, and vehicle stability is improved throughout extreme obstacle shunning manoeuvres.

Keywords: *Quality, Brakes, Automobile, Performance, Brake bias.*

1. INTRODUCTION

The behaviour of an automobile undergoing braking is critical in terms of both performance and passenger safety. The brakes are the single-most necessary safety part on an automobile, and are charged with the very important task of stopping the moving vehicle. The essential goals of braking systems are to decelerate a vehicle throughout stopping, to take care of vehicle speed throughout downhill operation, and to carry a vehicle stationary on a grade. The look goals of the swiftness side of the braking system will then be expanded. The braking system must slow the vehicle to a stop with an adequate retardation level. Subject to varied vehicle conditions (loading, etc.). In a manner that utilizes the maximum amount of the obtainable traction as potential over an oversized vary of road conditions. Without causing vehicle instability during braking events. In a manner that is predictable to the driver like many other aspects of automobile design, brake hardware is conventionally designed as a compromise between the different performance requirements. Furthermore, a factor of safety is designed into the components to assume close to worst case scenario road conditions, severely limiting performance in favourable conditions.

1.1 REVIEW OF LITERATURE

The mechanics of the brake devices found on today's cars are well established for many years, and are well summarized and represented by Heisler. Heisler states that "a hydraulic braking system may be a compact methodology of sending the driver's foot- pedal effort to the individual road-wheel brakes by transfer controlled fluid from one position to a different then changing the fluid pressure into helpful work on the wheels to use the brakes and then retard or stop the rotation of the wheels"(9). Limpert additional states that "when each axles area unit braked at comfortable levels so the front and rear wheels area unit operational at early or peak friction conditions, then the most traction capacity between the tire-road system is utilized"(9). Brake force proportioning is usually designed with a static front to rear quantitative relation to closely replicate the best braking force quantitative relation. This effect is not reflected in Limpert's analysis.

1.2 NEED OF BRAKE BAIIS BAR

These are the brakes within which we are able to change the clamping force (pressure within the Master Cylinder) at the front and therefore the rear brakes with the

assistance of balance bar (13). A balance bar may be a easy rod (threaded or not threaded) connected to the Push rods of the Master cylinder's (MCs) through clevises at each ends and pivoted by a spherical bearing.

distribution of force that goes to every hydraulic brake cylinder depends on the balance bar position. If the spherical bearing (located within the pedal housing) is positioned precisely within the Centre of the 2 hydraulic brake cylinder pushrod clevises, then each master cylinder transfers the same amount of pushrod force.

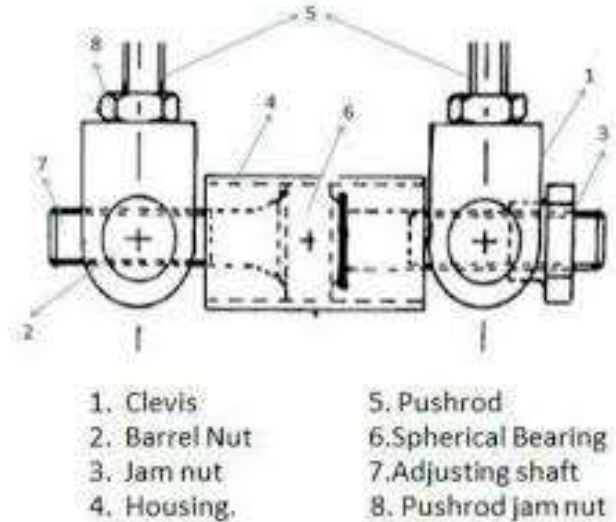
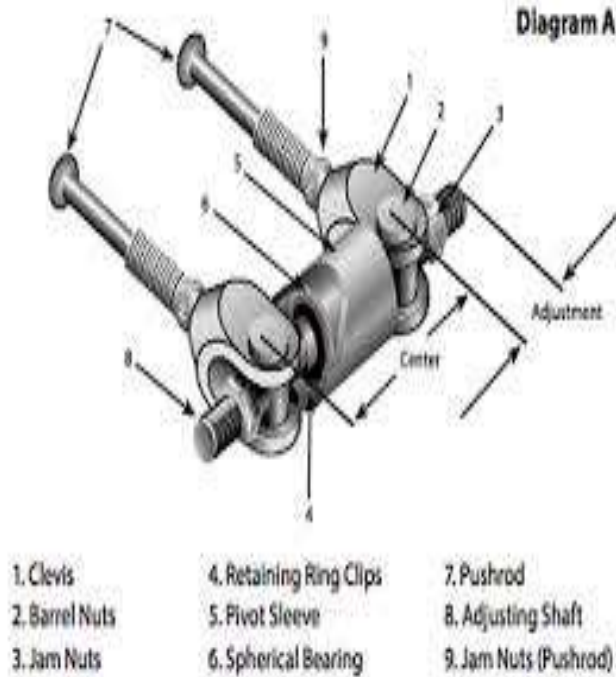

Fig- 2: Design of Bias Bar (6)

Fig -1: Bais Bar (11)

By adjusting the Rod the pivot position changes i.e. pivot comes close to either one amongst them and much far from different. When the balance bar is cantered, it pushes equally on both master cylinders creating equal pressure, given that the master cylinders are the same size bore, with the same calliper piston space it becomes troublesome to distribute the braking force at totally different wheels. This makes it hard to lock all the four wheels. Hence it is important to compensate with the change in the weight transfer. The optimum brake bias depends on the right track to trace and driver to driver. To provide the a lot of relative braking force at front we are able to increase the front disc diameter, pad area, calliper piston area or by reducing the bore diameter of front master cylinder than rear. This paper emphasizes the importance of using brake bias bar (also commonly known as balance bar) in the ATV. We fine tune the brake balance with the bias bar.

2. CONSRUCTION AND WORKING PRICIPLE

The construction of the balance bar is as shown in fig. (2). It consists of a solid threaded bar of specific diameter with a spherical bearing fitted on it. This assembly slides within the housing of the pedal with present length. The balance bar takes the force applied to the pedal and distributes it to the front (right) and rear (left) master cylinders. The percentage

Rotating the balance bar results in move the spherical joint relative to the 2 clevises. For example, if we turn the bar, the spherical joint moves closer to the left clevis, then the left clevis will experience more force from the pedal than the right clevis. A common idea in biasing is that ever-changing the length of the hydraulic brake cylinder pushrod can modification what quantity force every hydraulic brake cylinder gets as input, or that it will decide which master cylinder builds pressure first. This is wrong. Both piston chambers can begin to create pressure at a similar time and therefore the balance bar adjustment position can decide what proportion force is distributed to every master cylinder.

3. Types Bias Bar

3.1 SPHERICAL BEARING IN TUBE

For many years the foremost common form of balance bar system was a spherical bearing in a very tube within the pedal and a clevis connected to the tip of every hydraulic brake cylinder push rod. (Fig 3). The balance bar is mounted axially however unengaged to rotate the centre or inside the centre of the spherical bearing and rib into the push rod clevises (9). By rotating the balance bar the spherical bearing moves back and

forth inside the tube.

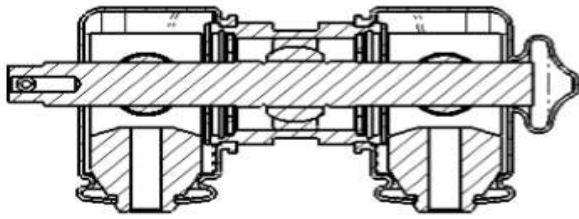

Fig -3: SPHERICAL BEARING IN TUBE (7)

3.2 CENTRE TRUNNION

In this type the spherical bearing is replaced by a center trunnion which is usually fixed in position midway between the two master cylinders. The center of the trunnion is threaded. The balance bar rotates inside clevises connected to the hydraulic brake cylinder push rods however isn't rib inside them. Rotating the balance bar causes the master cylinder trunnions to move over relative to the center trunnion. Fig 4. The master cylinder trunnion that moves closer to the center turn-on has its load increased. So in Fig. 3 turning the balance bar clockwise will increase the load on the proper hand cylinder. Because the center trunnion type angles over the cylinders more as it is adjusted further away from the mid position this should be kept to a minimum. Once the adjustment is larger than two or three turns it's higher to maneuver to subsequent size cylinder to bring the adjustment back close to middle position.

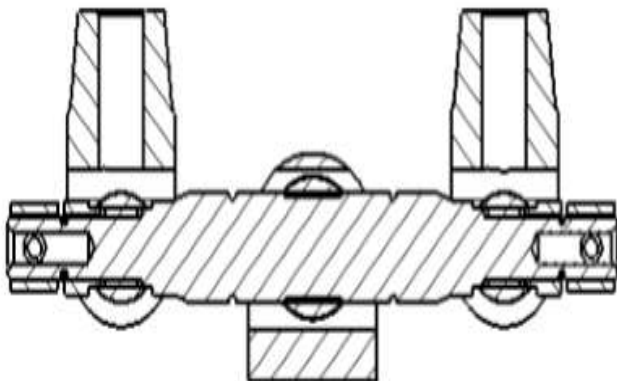

Fig-4: CENTRE TRUNNION (7)

Traditionally the balance bar is within the pedal with the clevis' or spherical bearings fitted to the piston chamber push rods however it may be fitted at the top of the master cylinders with clevis' or spherical bearings within the cylinder bodies(9). The latter methodology permits higher packaging and means that the balance bar doesn't travel through an arc affected by the pedal. The latter systems must be used with cylinders having rigid push rod / pistons whereas the former

can be used with articulating push rods and a rigidly mounted cylinder body.

4. Components of Brake Bias

Let's take a glance at the various elements that frame the hydraulic brakes. The complete braking system will be de-escalated into the subsequent main parts:

- Master cylinder
- Lines
- Fluid
- Caliper
- Pads
- Rotor

Next we are going to make a case for these parts in additional detail.

4.1 MASTER CYLINDER

The hydraulic brake cylinder, mounted to the bar, homes the brake lever and along they turn out the input force required to push brakes fluid to the slave cylinder (or caliper) and cause the brake pads to clamp the rotor.



Fig-5:Master Cylinder (10)

4.2 STEEL BRAIDED BRAKE LINES

Steel braided hoses will give some benefits over normal hydraulic hoses. Steel braided hoses are also usually a 3-layer construction, the inner most layer contains the brake fluid and there is an outer most layer which provides protection against abrasions. The key distinction is within the middle layer that is formed from a stainless-steel braid. This stainless-steel layer is intended to be additional resistant against enlargement than that of normal lines. This can be a bonus as a result of once the brake lever is applied we would like all of the force we tend to place in to be transferred to the caliper to cause braking(10). Any enlargement within the hydraulic line because of the pressures inside can mean that a number of that pressure won't

be transferred to the caliper. This will be wasted effort and will require additional lever input by the rider to compensate.

defines the pedal quantitative relation (4). Note that this relationship holds true despite the location of the output rod relative to the fulcrum:

4.3 BRAKE FLUID

Hydraulic braking systems generally use one among 2 varieties of brake fluid - DOT fluid or oil. An important factor to notice before we tend to get into the properties of every is that the 2 fluids ought to never be mixed. They are made up of very different chemicals and the seals within the braking system are suited to either fluid or not both; therefor mixing or replacing one fluid with the opposite is probably going to corrode the internals of your brake. On the opposite hand, mixing fluid from the same family is allowed but not generally advised. For example you'll combine DOT four fluid with DOT five.1 without harming your braking system



4.4 CALIPER

The brake calipers reside at each wheel and respond to the pedal input generated by the user. This lever input is regenerate to clamping force because the pistons move the constraint to contact the rotor. Calipers can be fixed by a rigid mount to the frame or floating. Fixed calipers are combined with a fixed rotor which offers the only way of achieving zero free running drag; one drawback of this design is that it is much less tolerant of rotor imperfection(8). Floating calipers slide axially and self-Centre with each braking application. The brake calipers reside at each wheel and respond to the pedal input generated by the user. This lever input is regenerate to clamping force because the pistons move the constraint to contact the rotor. Calipers can be fixed by a rigid mount to the frame or floating. Fixed calipers are combined with a fixed rotor which offers the only way of achieving zero free running drag, one drawback of this design is that it is much less tolerant of rotor imperfections. Floating calipers slide axially and self-Centre with each braking application.

Fig-7: BRAKE PEDALS (9)

Pedal quantitative relation (unit less) = distance, pad to pivot (in) / distance, output rod to pivot (in). Given the area and packaging limitations of a typical traveller vehicle, the most brake pedal ratio come-at-able is more or less five.5:1 to 8:1(11). A foot pedal with a better quantitative relation typically won't fit under the dash handily, a minimum of if you're making an attempt to switch the stock foot pedal arm to achieve this level of gain

4.5 ROTORS

Rotor size includes a direct impact on braking power. The larger the brake rotors the additional power are going to be made for any given input. This can be a priority with larger rotors as they have a tendency to possess additional of a 'grabby' feel creating the brake harder to modulate(8). Mountain bike rotors tend to place size from 160mm to 203mm, with smaller rotors engaged toward XC kind riding and bigger rotors designed for downhill riding.

5. PRESSURE CONTROL

In general, there are a unit 3 ways to modify rear brake pressure: leave it alone, create it proportional to the front brake pressure, or control it in a way that combines these two strategies (5). As shown in chart 1 the front brake pressure and rear brake pressure would always be equal. Naturally, this is often the simplest way to modify the problem, however so as to stop rear bias below all conditions, the rear brake itself would wish to be absolutely tiny.

4.6 BRAKE PEDALS

The foot pedal arm pure mathematics (the location of the output rod relative to the foot pedal pad and the fulcrum)

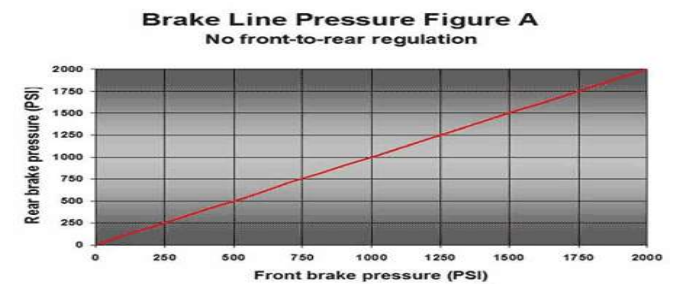

Chart No. 1: Pressure control(5)

6. FACTORS THAT WILL INCREASE

6.1 FRONT BIAS

- Increased front rotor diameter
- Increased front brake pad constant of friction
- Increased front calliper piston diameter(s)
- Decreased rear rotor diameter
- Decreased rear brake pad constant of friction
- Decreased rear calliper piston diameter(s)
- Lower centre of gravity (i.e. lowered vehicle)
- More weight on rear shaft (i.e. loaded)
- Less weight on front shaft
- Less sticky tires (lower fastness limit)

6.2 FACTORS THAT WILL INCREASE

REAR BIAS

- Increased rear rotor diameter
- Increased rear brake pad constant of friction
- Increased rear calliper piston diameter(s)
- Decreased front rotor diameter
- Decreased front brake pad constant of friction
- Decreased front calliper piston diameter(s)
- Higher center of gravity (i.e. raised vehicle)
- Less weight on rear shaft (i.e. unloaded)
- More weight on front shaft
- More sticky tires (higher fastness limit)

7. BRAKE BIASING RATIO

Establishes the quantitative relation of braking force between the front and rear wheels brakes. One of the foremost vital changes that a driver must create to an automobile whereas running is brake balance. Brake balance, called also brake bias, front to rear, is critical to the stability of a racing car during the braking and during turn-in phase; too much rear brakes will tend to cause the car to spin; too much front and car will not turn in

8. FINITE ELEMENT ANALYSIS

The finite element methodology may be a powerful tool to get the numerical answer of big selection of engineering issues. The method is usually enough to handle any advanced shapes or geometries, for any material under different boundary and loading conditions. The generality of the finite component methodology fits the analysis demand of present day's advanced engineering systems and styles wherever solutions of governing equilibrium equations square measure typically not

out there. In addition, it's an economical design tool by that designers will perform constant quantity design studies by considering varied design cases, (different shapes, materials, loads, etc.) and analyse them to choose the optimum design.

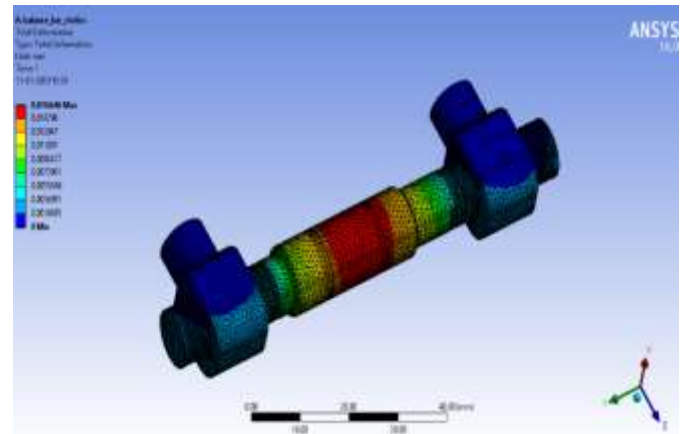

Fig-8: Total Deformation

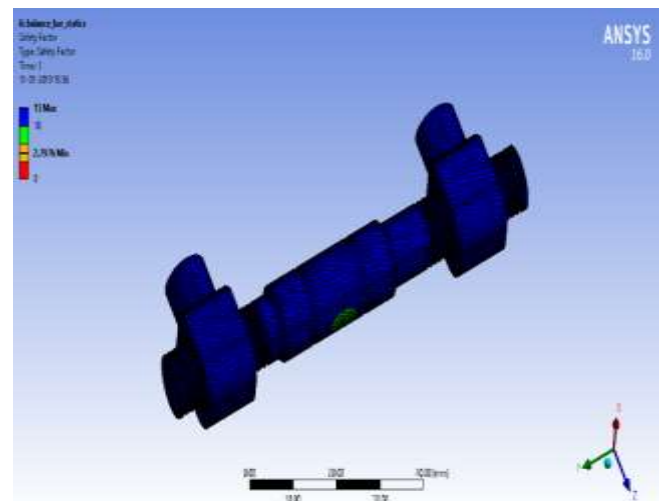

Fig-9: Safety Factor

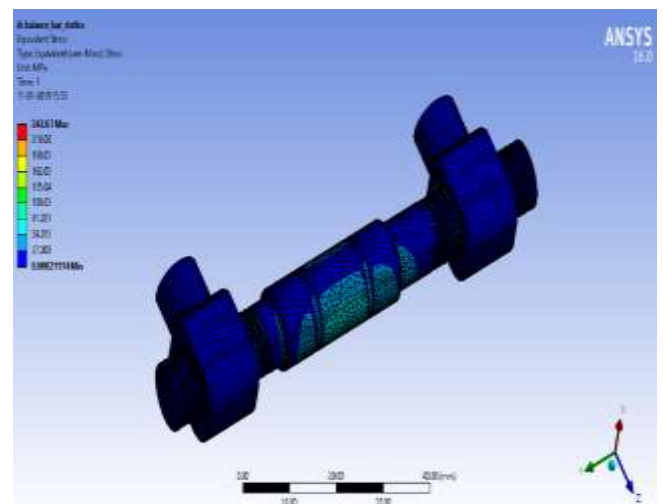

Fig-10: Equivalent stress

Table-1: Result

Total Deformation (mm)	0.0166
Safety Factor	15
Equivalent Elastic Strain (Mpa)	243.07

9. CONCLUSION

In this paper, numeric computations are done to get braking forces, braking force, clamping forces at callipers, brake bias and alternative necessary parameters in an exceedingly braking system. As you act modifying you're automotive for the road or for the track, remember that changes within the braking system furthermore as changes within the cars ride height, weight distribution, or physical dimensions will swing brake bias everywhere the place. The sole successful manner on knowing if your final bias has been optimized is to live stopping distance each before and once your modification.

REFERENCES

- [1] Carroll Smith, "Tune to win", year 1978.
- [2] William F. Milliken, Douglas L. Milliken, "Race Car Vehicle Dynamics", year 1995.
- [3]https://globaljournals.org/GJRE_Volume14/3-Balance-Bar-Design.pdf
- [4]Rutvik H Rana¹, Nishant H Jakhiya¹, Anand K Savani¹, Atmiya K Bhalodi¹"OPTIMUM DESIGN OF BRAKING SYSTEM FOR A FORMULA 3 RACE CARS WITH NUMERIC COMPUTATIONS AND THERMAL ANALYSIS" e-ISSN: 2395 -0056 Volume: 04 Issue: 02 | Feb -2017 www.irjet.net p-ISSN: 2395-0072
- [5] AP racing, www.apracing.com
- [6]Apurv Puranik, Harshal Jaju , Tejas Karambelkar"Brake Bias Bar Design and Simulation on a Formula Student Car" (ICIIME 2017) ISSN: 2321-8169 Volume: 5 Issue: 6 852 – 855

[7]<https://www.scribd.com/document/149397880/Balance-Bar-Systems>

(8)Subhash Mishra and Sagar Janghu"BALANCE BAR DESIGN AND MOTION ANALYSIS OF PUSHROD" ISSN 2278 – 0149 www.ijmerr.com Vol. 3, No. 3, July 2014

(9)<https://www.cncbrakes.com/ProdGroup.aspx?grp=dcbpa>

[10]<https://www.sae.org/publications/technical-papers/content/2014-01-2485/>

[11]<https://www.offroadxtreme.com/videos/tech-videos/other-tech/adjusting-brake-bias-using-balance-bar-tilton-engineering/>

