



A SURVEY ON AN AUTOMATIC SOLAR TRACKING SYSTEM

Shailaja Telang¹, Pooja Maindarkar², Umakant Gaulkar³

¹*UG Student, Electronics and Telecommunication, JDIET Yavatmal, Maharashtra, India, telang.shailaja@gmail.com*

²*UG Student, Electronics and Telecommunication, JDIET Yavatmal, Maharashtra, India, Pooja_maindarkar@yahoo.com*

³*UG Student, Electronics and Telecommunication, JDIET Yavatmal, Maharashtra, India, umakantgaulkar17@gmail.com*

Abstract

This is a survey paper on "An Automatic Solar Tracking System". During the day an automatic solar tracker follows the sun from east to west. As per the different intensity of the sun during the complete day, the generation of power is more with the help of an automatic solar tracker. The basic problem of the organic solar panel is the low efficiency. But the addition of an automatic solar tracker to the basic organic solar panels lead to improved solar panels. The efficiency of the solar panels with the solar tracking system is comparatively more than the efficiency of the solar panels without a solar tracking system. The integration of electrical and mechanical system together with the computer hardware and software together makes a complete solar tracking system. The solar tracking system works on the different software such as a microcontroller, embedded, ATmega328, IC555 etc. The single and dual axis trackers are the types of the solar tracking system. The construction, working, advantage, disadvantages, and applications of both the single and dual solar tracking system are described in this paper.

1. INTRODUCTION

The solar energy is the energy extracted from the rays of the sun in the form of heat and electricity. For all the life on the earth, this energy is essential. Solar energy is a renewable resource that is clean, economical and has less pollution compared to other resources and energy. Solar radiation consists of three parts. The direct radiation includes most of the energy. In remote areas the sun is the cheap source of energy thus it is highly used. But not just by using it is profitable it should be used efficiently. A majority of solar panels are stationary and also due to the rotation of the earth, it is difficult for panels to maintain the position always in front of the sun. Thus to overcome this problem different methods, ways are adopted but the more efficient way is 'an automatic solar tracking system'. The automatic solar tracker is completely automatic and keeps the panel in front of the sun until the sun is visible. The unique feature of this system is that instead of taking the earth as in its reference, it takes the sun as a guiding source. Its active sensors constantly monitor the sunlight and rotate the panel towards the direction where the intensity of sunlight is maximum. In case the sun gets invisible e.g. in cloudy weather, then without tracking the sun an Automatic Solar Tracking System keeps rotating the solar panel in opposite direction to the rotation of the earth. But its speed of rotation is same as that of earth's

rotation. Due to this property when after some time when the sun again gets visible, the solar panel is exactly in front of the sun. And again when the weather is sunny it faces towards the sun where the intensity is maximum. This paper gives the overall knowledge about an automatic solar tracking system.

2. SOLAR PANELS

The solar panels absorb the sunlight as a source of energy to generate electricity or heat. A photovoltaic (PV) module is a packaged, connected assembly of a typically 6x10 photovoltaics solar cells. Photovoltaics module constitutes the photovoltaic array of a photovoltaic system that generates and supplies solar electricity in commercial and residential applications. Photovoltaic modules use light energy (photons) from the sun to generate electricity through the photovoltaic effect. A typical simple cell has two layers of silicon. One is known as n-type. The other is p-type. The layers are different from each other. The process of making electricity begins when the silicon atoms absorb some light. The light's energy knocks some electrons out of the atoms. The electrons flow between the two layers. The flow makes an electric current. The current can leave the cell through the metal contacts and be used. When light hits a solar cell, much of its energy is wasted. Some light bounces off or passes through the cell. Some

are turned into heat. Only light with the right wavelengths, or colors, is absorbed and then turned into electricity. Fig. 1 shows the working of the solar cell.

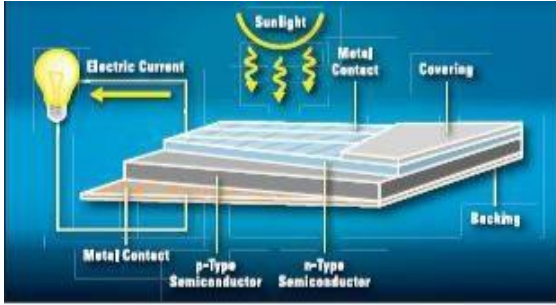

Fig. 1 Basic Solar Cell

3.SINGLE AXIS AUTOMATIC SOLAR TRACKER

A single axis solar tracker has only one axis movement, usually aligned with the North and South. This allows the panels to arc from the East to West, tracking the sun as it rises, travels across the sky, and seas. Single axis trackers tend to be better for companies with the lower budget or for areas with frequent cloud cover.

3.1 Construction and working

Here, for example, a single axis solar tracker used works on the Microcontroller. The Microcontroller used in single axis solar tracker system is PIC16F877A.

The block diagram for the single axis solar tracker is shown below in fig. 2.

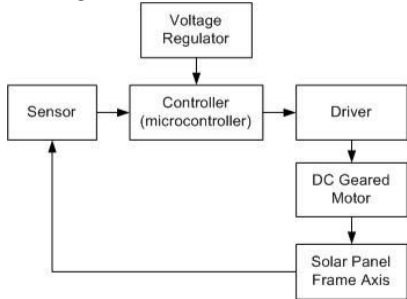

Fig.2. Block Diagram of Single Axis Solar Tracker

The block diagram consists of,

1. Sensor - Light Dependent Resistor (LDR) as a light sensor are used. The two light sensor are separated by the divider which will create the shadow on one side of the light sensor if the solar panel is not perpendicular to the sun.
2. Voltage Regulator – It is used to regulate the voltage.
3. Controller – Microcontroller PIC16F877A acts as a brain that controls the movement of the motor via a relay. Data received from the sensors and processed by the microcontroller.
4. Driver – It drives the controller output to the DC Geared Motor.
5. DC Geared Motor - DC-g geared motor via relay is used to ensure solar panel is perpendicular towards the Sun. Relay controls the rotation of the motor either to rotate clockwise or anticlockwise.
6. Solar Panel Frame Axis - The solar panel that attached to the motor will be reacted according to the direction of the motor.

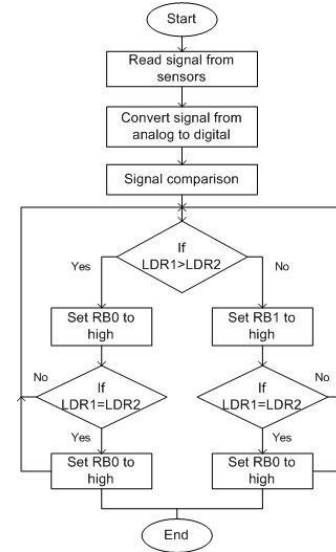

Fig.3.Programming of Single Axis Solar Tracker

The observation table for the single axis tracker is given below in Table No.1 [2]

Hours	From static solar panel			From solar tracking system		
	V	mA	mW	V	mA	mW
8:00 AM	16.8	1.23	20.664	18.3	3.41	62.403
9:00 AM	17.0	2.34	39.780	18.9	3.57	67.473
10:00 AM	17.6	2.51	44.176	19.4	3.98	77.212
11:00 AM	19.4	3.64	70.616	19.7	4.76	93.772
12:00 PM	19.8	4.45	88.110	20.4	5.40	110.430
1:00 PM	20.5	5.12	104.960	21.6	6.35	137.160
2:00 PM	21.1	5.94	125.334	21.4	6.11	130.754
3:00 PM	19.4	5.43	105.342	20.5	5.87	120.335
4:00 PM	17.2	5.01	86.172	19.6	5.26	103.096
5:00 PM	16.5	4.28	70.620	18.5	4.86	89.910
6:00 PM	16.2	2.87	46.494	17.5	3.75	65.625

Total power by static solar panel = 802.268 ≈ 803W
 Total power by solar tracking system = 1058.17 ≈ 1058W
 %Efficiency = [(1058-803)/803]*100 = 31%
 According to the above observations, the increase in the efficiency is about 31%. Thus the use of solar tracker helps to increase the efficiency of solar panels.

3.2 Advantages

1. Generally lower in cost than dual-axis trackers.
2. Higher reliability than the dual-axis trackers.
3. Higher lifespan than the dual-axis trackers.

3.3 Disadvantages

- 1 Lower energy output during sunny conditions when compared to dual-axis trackers.
- 2 Fewer technological advancements.

3.4 Application

Solar trackers can either have a horizontal or a vertical axis. The horizontal type is used in tropical regions where the sun gets very high at noon, but the days are short. The vertical type is used in high latitudes where the sun does not get very high, but summer days can be very long. In concentrated solar power applications, single axis trackers are used with parabolic and linear Fresnel mirror designs.

4. DUAL AXIS AUTOMATIC SOLAR TRACKERS

A dual axis trackers have two axes of movement, aligned with North-South and with East-West, giving them a wide range of position options. As seasons changes and the sun's path goes from low in the sky in winter too high in the sky in summer, dual axis trackers can optimize the amount of solar energy captured.

4.1 Construction And Working

Here, for an example, dual axis solar tracker works on Microcontroller. The Microcontroller used in the dual solar tracker is PIC 16F72.

The block diagram for the dual axis solar tracker is shown below in fig. 4.

The block diagram consists of,

1. Sensor Board – Light Dependent Resistor (LDR) as a light sensor are used.
2. Microcontroller – Microcontroller PIC 16F72 acts as a brain that controls the movement of the motor.

Data received from the sensors and processed by the microcontroller.

1. Stepper Motor – The motor is used to position the solar panel where it can receive maximum sunlight.
2. Mechanical Interface –It gives the interface of the output of the stepper motor with the PV Array
3. PV Array – It is an array of many solar panels.

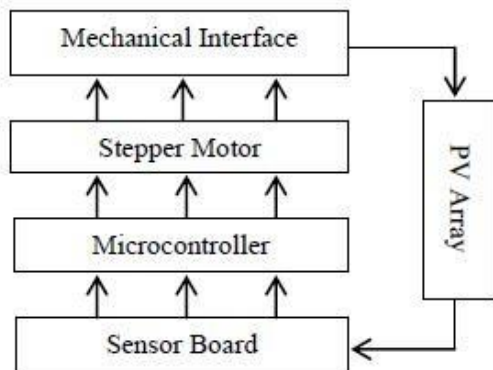

Fig. 4 System Block Diagram

The observation table for the dual axis tracker is given below in Table No.2 and Table No.3 [1]

Table 2. Data with Auto Tracking System

Time	Pyrheliometer Reading (mV)	Intensity (Wm ⁻²)	Single Panel Current (A)	Single Panel Voltage (V)	SPP with Tracking (W)	4 SPP with Tracking (W)
8:40	3.4	607.14	2.4	17.45	41.88	27.808
8:50	3.4	607.14	2.43	17.48	42.476	28.204

9:00	3.5	625	2.44	17.4	42.456	28.190
9:10	3.6	642.85	2.47	17.49	43.200	28.685
9:20	3.6	642.85	2.48	17.48	43.350	28.784
9:30	3.5	625	2.5	17.53	43.825	29.099
9:40	3.6	642.85	2.53	17.55	44.401	29.482
9:50	3.6	642.85	2.57	17.56	45.129	30.198
10:00	3.6	642.85	2.59	17.56	45.480	30.652
10:10	3.5	625	2.65	17.42	46.163	30.652
10:20	3.6	642.85	2.72	17.44	47.436	31.498
10:30	3.6	642.85	2.77	17.46	48.364	32.113
10:40	3.7	660.71	2.8	17.39	48.692	32.331
10:50	3.8	678.57	2.86	17.37	49.678	32.986
11:00	3.9	696.42	2.89	17.33	50.083	33.255

Total Power with Auto Tracking System= 453.250

Table 3. Data without Auto Tracking System

Time	Pyrheliometer Reading (mV)	Intensity (Wm ⁻²)	Single Panel Current (A)	Single Panel voltage (V)	SPP Without Tracking (W)	4 SPP Without Tracking (W)
8:40	3.4	607.14	2.1	17.05	35.805	23.774
8:50	3.4	607.14	2.15	17.1	36.765	24.411
9:00	3.5	625	2.21	17.28	38.188	25.357
9:10	3.6	642.85	2.23	17.3	38.579	25.616
9:20	3.6	642.85	2.26	17.41	39.346	26.126
9:30	3.5	625	2.27	17.43	39.566	26.271
9:40	3.6	642.85	2.31	17.55	40.540	26.918
9:50	3.6	642.85	2.37	17.5	41.475	27.539
10:00	3.6	642.85	2.39	17.54	41.920	27.835
10:10	3.5	625	2.41	17.42	41.982	27.876
10:20	3.6	642.85	2.46	17.44	42.902	28.487
10:30	3.6	642.85	2.46	17.46	42.951	28.519
10:40	3.7	660.71	2.47	17.39	42.953	28.520
10:50	3.8	678.57	2.6	17.37	45.162	29.987
11:00	3.9	696.42	2.64	17.33	45.751	30.378

Total Power without Auto Tracking System= 407.614

Power Calculation from Table 2 and Table 3:

Power without tracking = 453.250 WH ≈453

WH Power with tracking =407.614 WH ≈408

WH

Extra power for tracking, = (453-408) WH = 45

WH Increased power = [(453-408) /408]*100% =

11.09 %

The increased in the power after comparison is approximately equal to 12%. The above tables give the power rating from 8:40am to 11:00am only the whole day up to 5:00pm gives up to approximately 15% increase in power

4.2 Advantages

1. Higher degree of flexibility, allowing for a higher energy output on sunny days,
2. A Higher degree of accuracy in directional pointing.

4.3 Disadvantages

- 1 Higher mechanical complexity, making it more likely for something to wrong.
- 2 Lower lifespan and lower reliability.
- 3 Unreliable performance in cloudy or overcast weather.

4.5 Application

Solar trackers have both a horizontal and a vertical axis and thus they can track the sun's apparent motion virtually anywhere in the world. CSP applications using dual axis tracking include solar power towers and dish systems. Dual axis tracking is extremely important in solar power applications due to the angle errors resulting from longer distances between the mirror and the central receiver located in the tower structure. Many traditional solar PV applications employ two-axis trackers to position the solar panels perpendicular to the sun's rays. This maximizes the total power output by keeping the panels in direct sunlight for the maximum number of hours per day.

Fig.5 shows a flowchart of PIC16F72 programming that is used in the single axis solar tracker.

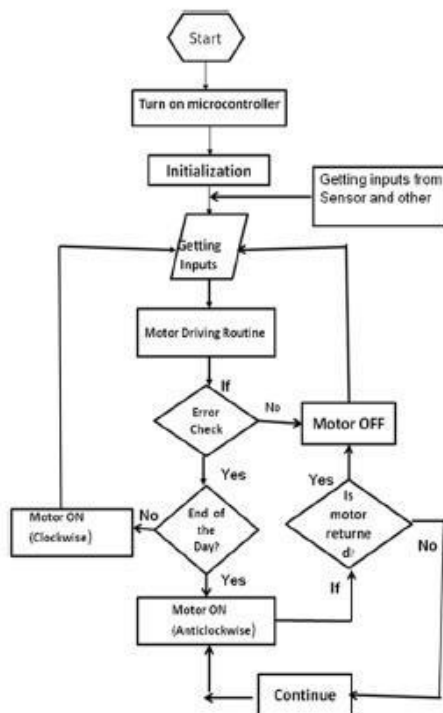

Fig.5. Programming of Dual Axis Solar Tracker

5. ADVANTAGES AND DISADVANTAGES OF AUTOMATIC SOLAR TRACKING SYSTEM

5.1 Advantages

1. Solar trackers generate more electricity than their stationary counterparts due to an increased to direct exposure to solar rays.
2. Both the single-axis and dual-axis trackers help to find the perfect fit for the unique job site, and electrical requirements are all important consideration that can influence the type of solar tracker to be used.
3. Solar trackers generate more electricity in roughly the same amount of space needed for fixed tilts systems, making them ideal optimizing land usage.

5.2 Disadvantages

- 1 Solar trackers are slightly more expensive than their stationary counterparts, due to the more complex technology and moving parts necessary for their operation.
- 2 Some ongoing maintenance is generally required, though the quality of the solar tracker can play a role in how much and how often this maintenance is needed.

6. CONCLUSION

In this survey as guessed already that, there is no objective winner here. Both the Single-Axis Solar Tracking System and Dual-Axis Solar Tracking System have advantages and disadvantages and can be useful under the different scenarios. Companies need to assess various factors like location, cost, maintenance, efficiency, and reliability when making this decision. As per the need any of the tracking systems can be used for better output. And it clear from the above survey reports solar panels with Tracking System is more better and efficient than the solar panels without Tracking System. It can either be Single-Axis Solar Tracking System or Dual-Axis Solar Tracking System.

7. ACKNOWLEDGEMENT

I would like to confer the flower of acknowledgment to my college Jawaharlal Darda Institute of Engineering and Technology Yavatmal for giving me chance to show my skills. I would like to take this opportunity to thank Department of Electronics and Telecommunication Engineering and to our Guide Asst. Prof A.B. Rathod and Co-Guide Asst. Prof R.G. Mundada for the encouragement and the support they have extended and for their guidance.

REFERENCES

- [1]. M. M. H. Prodhan, M. K. Hamid, D. Hussain, M. F. Huq. "Design, Construction and Performance Evaluation of an Automatic Solar Tracker."
- [2]. Asmarashid Ponniran1, Ammar Hashim, Ariffuddin Joret. "A Design of Low Power Single Axis Solar Tracking System Regardless of Motor Speed." International Journal of Scientific & Engineering Research, Volume 4, Issue 6, June-2013 93 ISSN 2229-5518 IJSER © 2013 <http://www.ijser.org>
- [3]. "AUTOMATIC SOLAR TRACKER SYSTEM." ISO 9001:2008 Certified International Journal of Engineering Science and Innovative Technology (IJESIT) Volume 2, Issue 2, March 2013 425
- [4]. "Comparison of Efficiencies of Single-Axis Tracking System and Dual-Axis Tracking System with Fixed Mount."
- [5]. <http://www.advantages and disadvantages of solar tracker system.html>
- [6]. <http://www.difference between single and dual axis trackers .html>
- [7]. <http://www.single and dual axis tracking: advantages and disadvantages .html>