



INTERNATIONAL JOURNAL FOR ENGINEERING APPLICATIONS AND TECHNOLOGY

“OPTIMIZATION OF PARAMETER OF THREE PHASE INDUCTION MOTOR DESIGNING BY USING TECHMO”

Vrushabh R. Bhagadkar¹, Pragati S. Dhote², Prachi M. Gharde³, Pooja V. Hiwrale⁴

*1*Vrushabh R. Bhagadkar, BE Pursuing, Dept of Electrical Engineering, JDIET Yavatmal, Maharashtra, India, vrushabhbhagadkar12@gmail.com

*2*Pragati Dhote BE Pursuing, Dept of Electrical Engineering, JDIET Yavatmal, Maharashtra, India, pragatidhote1997@gmail.com

*3*Prachi Gharde, BE Pursuing, Dept of Electrical Engineering, JDIET Yavatmal, Maharashtra, India, prachigharde.20@gmail.com

*4*Pooja Hiwrale, BE Pursuing, Dept of Electrical Engineering, JDIET Yavatmal, Maharashtra, India, poojahiwrale123@gmail.com

Abstract

In these paper represent the designing parameter for 3 phase induction motor. These papers introduce optimization in induction motor designing by using software. In these papers assume the efficiency of an induction is 84% and power factor 0.80 and also considering some variable for designing. The motor parameter such as stator resistance, rotor resistance, rotor current induction motor losses are presented in this paper. The analysis is performed by using TECHMO software which is a powerful tool to analyse the performance and design of machines.

Keyword:- Parameter Calculation of Induction Motor, losses, Power Factor, Efficiency, Techmo etc.

1. INTRODUCTION

Although the design procedures for induction motors are well established, there are some areas which require special contemplation. The manual design of motor account for lengthy calculations and any changes in parameters for an acceptable design leads to recalculation. Thus precious time and diligence of the designer is required to carry out the calculations accurately. To cite an example, after computer the calculations of an induction motor design it has been observed that performance of the machine is not satisfactory and dimension of the machine is uneconomical. To solve this, the designer has to change some design parameters like electric loading, magnetic loading, insulation thickness, length of air gap, ampere per conductor etc. Hence an iterative calculation of the entire design procedure is required to achieve a satisfactory result. The approximations assumed in the manual calculations also lead to inaccurate results. Techmo Software in fact that computers can perform a very large number of calculations in short time. The essential thing is that it has to be suitably optimized the design of three phase induction motor. The design features of an induction motor are classified as constructional wise and performance wise and the results are combined. The Techmo software used in manufacturing the motors are expensive and owned by private companies who cannot disclose the details of it.

2. MECHANICAL DESIGN PERSPECTIVES OF INDUCTION MOTOR

The stator and rotor magnetic cores are made of thin silicon steel laminations with non grain-to reduce hysteresis and eddy current losses. The stator and rotor laminations are packed into a single stack which is shown or in a multiple stack shown. The latter has radial channels (5-15 mm wide) between elementary stacks (50 to 150 mm long) for radial ventilation. Single stacks are adequate for axial ventilation. Single-stack induction motors have been traditionally used below 100 kW but recently have been introduced up to 2 MW as axial ventilation has been improved drastically. The multistack concept is necessary for large power (torque) with long stacks. The multiple stacks lead to additional winding losses, up to 10%, in the stator and in the rotor as the coils (bars) lead through the radial channels without producing torque. Also, the electromagnetic field energy produced by the coils (bar) currents in the channels translates into additional leakage inductances which tend to reduce the breakdown torque and the power factor. They also reduce the starting current current and torque. Typical multistack Induction motor are shown in For induction motors of fundamental frequency up to 300 Hz, 0.5 mm thick silicon steel laminations lead to reasonable core losses 2 to 4 W/Kg at 1T and 50 Hz. For higher fundamental frequency, thinner laminations are required. Alternatively, anisotropic magnetic powder materials may be used to cut down the core losses at high fundamental frequencies, above 500 Hz.

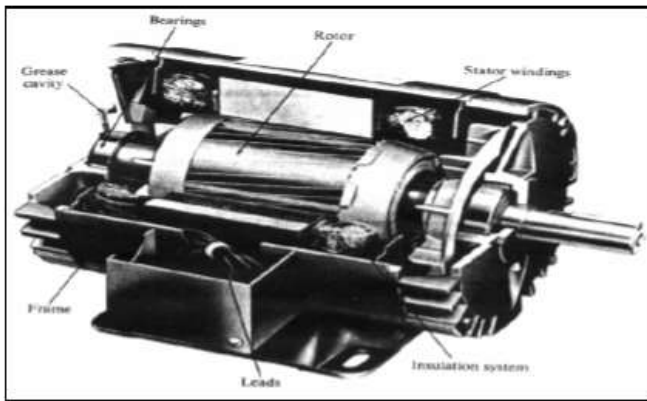

Fig 1. Induction motor wound three-phase stator winding with cage rotor

3. PARAMETER CALCULATIONS

3.1 Construction Details

Consider 3.7 Kw, 400Volt, 3ph, 4Pole, 50Hz for this rating assume Average flux density = 0.45 Wb/m^2 ampere. Conductor/meter ac = 22000, Efficiency = 0.85 and P.F. = 0.84. Also assume Winding Factor = 0.955 and Stack Factor = 0.9.

- Main Dimension:-
 kVA Input $Q = Kw / \eta \cos \phi = 5.18$
 Output coefficient $C_o = 11 * Kw \beta_{av} ac * 10^3 = 110.93$
 Synchronous Speed $\eta_s = 2F/P = 25 \text{ rps} / d^2 L = Q / C_o \eta_s = 1.86 * 10^{-3}$
 From there above calculation we are calculating Diameter and Length of motor. In these calculation designing motor for good power factor and efficiency ($L/\tau = 1.25$)
 $L/\pi D/P = 1.25$ or $L/D = 1.25 * \pi/p = 0.9817$
 Now, $D^2 L = 1.86 * 10^{-3} \text{ m}^3$ or $0.9817 D^3 = 1.86 * 10^{-3} \text{ m}^3$
 $D = 0.117$ and $L = 0.13$
 Pole Pitch $\tau = \frac{\pi D}{p} = 0.094 \text{ m}$
 And Net iron length $L_i = 0.108 \text{ m}$
- Turn /Phase:-
 Flux/ Pole $\phi_m = \beta_{av} L \tau = 5.86 * 10^{-3} \text{ Wb}$
 Stator turn/ phase $T_s = E_s / 4.44 F \phi_m K_w = 321.96$
- No. Of Slots (Stator Design):-
 Considering slot per pole/phase $q_s = 3$
 Total no. of stator slot $q_s = 3 * 4 * 3 = 36$
 Slot Pitch $Y_{ss} = \pi D / S_s = 0.01047 \text{ m} = 10.47 \text{ mm}$
 Now, Total number of stator conductor = $6 T_s = 1931.76 = 1932$
 Conductor/Slot $Z_{ss} = 1932/36 = 54$
 Actual number of Turn/Phase $T_s = 324$
- Winding Details:-
 For this small machine ,single layer winding placed in semi-enclosed slot is used. In a single layer each coil occupies two slots ,therefore
 No. Of coil = $36/2 = 18$
 Coil/ Phase = $18/3 = 6$

3.2 Parameter Calculations For Power Losses And Efficiency

Input Power:

$$P_{in} = \sqrt{3} V_L I_L \cos \theta = \sqrt{3} * 400 * 7.9 * 0.8 = 4310$$

The input power of the induction motor is 4310W

Efficiency calculation:

$$\eta = (1 - P_{losses}/P_{in}) * 100\%$$

Losses calculation

$$P_{losses} = P_{SCL} + P_{RCL} + P_{core} + P_{F+W} + P_{stray}$$

Stator copper loss:

$$P_{scl} = 3 I_1^2 R_1$$

Rotor copper loss:

$$P_{RCL} = 3 I_2^2 R_2$$

The Shaft Load Torque

$$\tau = P_{out} / \omega_{in} = 3730 / 1420 * 2\pi (1 \text{ min} / 60 \text{ s}) = 24.88 \text{ N.m}$$

Air gap power

$$P_{AG} = 3 I_2^2 \left(\frac{R_2}{s} \right)$$

Per-Phase Stator Core Loss Resistance:

$$R_c = V_{L1} / \sqrt{3} I_c$$

Per-Phase Stator Magnetizing Inductor:

$$L_{in} = V_{L1} \sqrt{3} / 2\pi f_s I_m$$

Value at 1 kW is 2.5%

of the full-load input power, dropping at 10kW to 2%, at

100kW to 1.5%, at 1000kW to 1%, and at 10 MW to 0.5%.

$$P_{Stray (IEEE)} = 4310 * 2.5\% = 107.75$$

standard, these losses are not measured and are arbitrarily estimated to be equal to 0.5% of the full-load input power.

$$P_{Stray (IEEE)} = 4310 * 0.5\% = 22.7 \text{ W}$$

In Ontario Hydro' s simplified segregated loss method suggests that one way around this obstacle is to assume a value for a combined windage, friction and core losses [11]. The study recommends that these combined losses be set to 3.5% of the input rated power.

Therefore, obtained rotational losses:

$$P_{ROT} = 3.5\% * 4310 = 150.85 \text{ W}$$

Factors to be consider: $I_1 > I_2$, I_1 must be bigger than I_2 value because $I_1 = I_2 + I_0$. The lower the horse power of the motor that increases the total resistance.

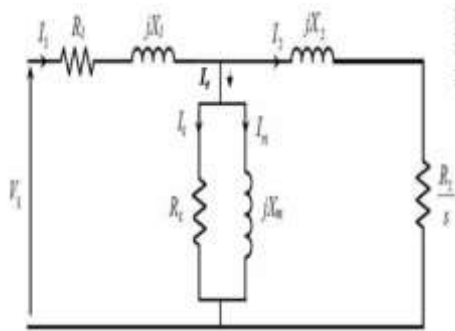

Fig 2. Equivalent Circuit of the AC Induction Motor.

motor with help of “ AC Electric Techmo Software”. You just need to enter a few preliminary input and click a buttons. what you get is an output design sheet containing more than 100 output parameters required to build an ac squirrel cage electric motor. You can start to design from a small fractional horse power AC electric motor to a 3.37 KW ac electric motor using this design data to match your specification and need. you can change any parameter from the design data sheet like no. of slots type, cage material material(Cu), length of stator, etc.

Designing Procedure :-

- Enter your primary input values like .kw or hp, auto conversion available.
- Enter your designing rated supply voltage window, supply frequency from drop down windows in supply frequency.
- Enter your designing machine pole.
- If you enter all variable value then gives run command for designing.
- The output is ready for construction of machine.

3.3 Loss Segregation Obtained From Calculation

Losses Segregation	Calculated value (W)
Input Power(Pin)	4310
Stator Copper Loss	410
Rotor Copper Loss	150
Core Loss+ Friction & Windage Loss	150.85
Stray Losses (Pstray)[1]	107.75
Stray Losses (Pstray)[2]	22.7
Output power (Pout)	3700

TABLE I: Loss Segregation Obtained from Calculation

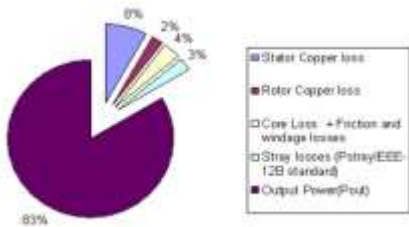

Fig 3. Percentage of Loss Segregation of 3.7 kw Induction Motor.

Based on Fig 5, it shows that the stator copper loss contribute 8% towards the losses followed by the core loss (4%). Stray loss (3%) and finally the rotor copper loss (2%).17% from the 3.7kw induction motor is dissipated as losses. and the balance 83% is the output power of the induction motor.

4. DESIGNING ON SOFTWARE

4.1 TECHMO

TECHMO present an easy way to design small & medium size of induction machine.3 phases and squirrel cage ac electric

RESULT

Calculated parameter	Theoretical value	Software output
Output coefficient (Co)	110.93	104
Diameter (D)	126mm	117 mm
Core Length (L)	130mm	124.31mm
Flux/pole(φm)	5.86Wb	5.56Wb
Pole pitch(τ)	94mm	99.45mm
Conductor/slot(Zss)	54	57
Net iron length (Li)	108mm	111.88mm
Stator turn/phase(Ts)	322	339
No. of stator slot(Ss)	36	36
Slot pitch(Yss)	10.47mm	11.05mm
No. of stator conductor	1932	2035

TABLE II: Comparing calculated output with software output

From the table II gives variation in theoretical output values and software generated output. Hence it generates output for optimizing the system.

CONCLUSION

The following conclusion could be made on this paper.

- A proper parameter calculation is needed to obtain the range of specification of the induction motor such as the total resistance, reactance, the losses estimation, stator current, rotor current, etc.
- It is noted that if the horse power rating of the induction motors increases the value of resistance decreases.
- As we using software for designing the 3 ph Induction motor, firstly we need to study the parameter which is important for designing or calculating the losses & efficiency.

- In these introducing the software TECHMO, which gives output value with various parts dimension, current value etc.

ACKNOWLEDGEMENT

As we present our paper on “OPTIMIZATION OF PARAMETER OF 3PHASE INDUCTION MOTOR DESIGNING BY USING TECHMO”, we take this opportunity to offer our sincere thanks to all those without whose guidance this paper, might have remained a dream for us. We express our deepest gratitude and thanks to Prof. Prajwal Kale and Prof. Akshay Shirbhate . whose guidance and ideas channelled our consciousness endeavours towards the paper.

REFERENCES

- [1]. D. Lindenmeyer, H.W. Dommel, A. Moshref, P. Kundur, “An induction motor parameter estimation method”, Electrical Power and Energy Systems 23 (2001) 251-262
- [2]. D. Lindenmeyer, H.W. Dommel, A. Moshref, P. Kundurb, “An induction motor parameter estimation method”,

Department of Electrical and Computer Engineering, The University of British Columbia, August 2000

[3]. Rui Esteves Araujo, Americo Vicente Leite, Diamantino Silva Freitas, “Estimation of Physical Parameters of an Induction Motor Using an Indirect Method” Faculty of Engineering University of Porto.

[4]. Marin Despalatovic, Martin Jadric, Bozo Terzic, “Identification of Induction Motor Parameters from Free Acceleration and Deceleration Tests”, ISSN 0005-1144 ATKAAF 46(3-4), 123- 128 (2005).

[5] Sinisa Jurkovic, “Induction Motor Parameters Extraction”.