



## A REVIEW ON MONITORING THE PARAMETERS OF THREE PHASE INDUCTION MOTOR USING ZIGBEE

**Dhanashri P. Kandalkar<sup>1</sup>, Sneha P. Maske<sup>2</sup>, Prof. A. B. Nagdewate<sup>3</sup>**

<sup>1</sup>UG Scholar, Electrical Engineering, DES's COET, Dhamangaon (Rly.), Maharashtra, India,  
*dhanashrikandalkar24@gmail.com*

<sup>2</sup>UG Scholar, Electrical Engineering, DES's COET, Dhamangaon (Rly.), Maharashtra, India,  
*snehamaske28@gmail.com*

<sup>3</sup>Assistant Professor, Electrical Engineering, DES's COET, Dhamangaon (Rly.), Maharashtra, India,  
*ashvini.bhaskar@gmail.com*

**Abstract**

Three Phase Induction motor is mostly used in the large scale industries. As wired communication of three phase induction motor is expensive and considering the physical condition, it is not safe for human. Hence, we preferred the wireless monitoring system to avoid the drawbacks in the operation of Induction motor. The aim of this paper is to monitoring the parameters of IM i.e. current, voltage, power and temperature. A low cost system for measuring the parameters with ZigBee protocol described in this paper. Data Acquisition System (DAS) saves all received data of the motor in database. Received values are sends through wireless network, data sense by the ZigBee coordinator which connected to computer through RS232 serial communication. In this way, this paper presents the comprehensive review of monitoring parameters of IM.

**Index Terms:** Current, Monitoring, Power, Three Phase Induction Motor (IM), Voltage, ZigBee.

\*\*\*

**1. INTRODUCTION**

Three phase induction motors are generally used in industrial drives because they are simple, reliable, rugged and economical. Fault is inducing in Induction Motor due to variation in Induction Motor parameters. Due to this fault the winding of motor get burned which produce insulation damage and thus reduce the life time of Motor. Monitoring the parameters of an IM is advance technology for the detection of initial faults. It avoids unexpected failure of an industrial process. Nowadays, necessity of monitoring the parameters of IM increased because of the widespread use of automation and consequently reduction in direct man-machine interface to supervise system operation. Monitoring of parameters is important to mitigate the consequential injury, to extend life of machine, reducing inventories of spare parts.

Monitoring techniques are categorized into two ways:

- Classical monitoring techniques
- Digital monitoring techniques

Classical monitoring techniques is a combination of electrical and mechanical monitoring equipment which wired system. Efficiency and reliability of the system minimize by classical monitoring. Another is digital monitoring which has several techniques such as microcontroller based protection system but it has drawback that result not displayed on the screen. PLC based fault protection system has been implemented

which shows the type of fault on screen but data can't stored and display as well as system is more expensive. Digital system reduces the cost as compared to classical and reduces time for detection of defects. Communication needs in many factories are served by wired technologies. Same kind of services are provided by the wireless technologies. As compared to above techniques ZigBee wireless technology is superior. In comparison with Wi-Fi and Bluetooth, ZigBee having large range and greater flexibility. In industries ZigBee is widely used in various ways because it aid devices having energy saving capacity and intelligent network topologies. Various types of protection relays such as over current relays, temperature relays, low and high current protection relays and time relays uses for protecting motors in classical monitoring to avoid defects. They increase cost and reduce sensitivity and efficiency. But in digital system like ZigBee wireless monitoring overcome all drawbacks. Hence, ZigBee wireless technology is preferred. This paper aims at exposing comprehensive survey on the monitoring parameters of IM.

**2. WIRELESS ZIGBEE TECHNOLOGY**

The ZigBee (IEEE 802.15.4) is a wireless technology which allows the installation of Wireless Personal

Area Networks (WAPN). It has several advantages such as low power consumption, low cost, greater flexibility, small as well as large distance communication with large range etc. WPAN's of ZigBee having frequencies of 2.4 GHz with 250 kbps data rate. This data rate is best suited for the two way data transmission between controllers and sensors. Routers extend the ZigBee network for connecting large area network. In ZigBee network the devices are categorized into three types: ZigBee Coordinator (ZC) - It is initiator of wireless network. Computer communicates with the ZigBee using coordinator. AT and ATP are the coordinators type. Without coordinator the network connection is not possible. ZigBee Router (ZR) - It is mediator. It helps to increase the strength of the signals that received from coordinators and sends to the end device. The number of routers can be used for the huge area network. ZigBee End Device (ZED) - It is portable device which find a new parent if lost the old one. Routing of data operation is not possible but can sleep when not transmitting.

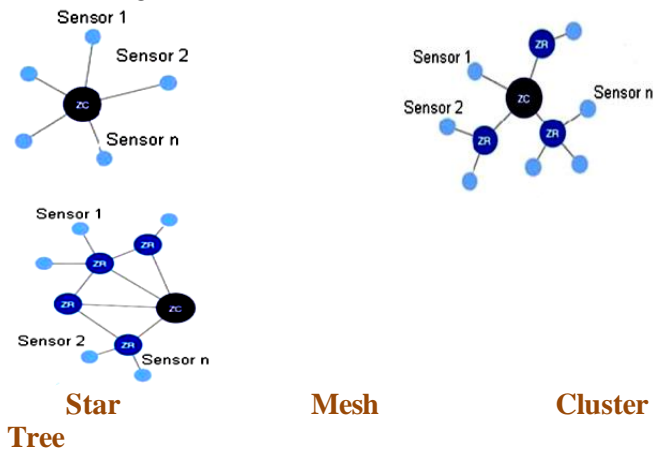

**Fig-1: Topology types for wireless sensor networks**

Different ZigBee topologies illustrated as below: Mesh, Star and Cluster Tree. Pictorial representation of topologies is shown in above fig-1.

Star Topology - includes the coordinator and various end devices. In this topology, coordinators only interact with end device.

Mesh Topology – as redundancy is important aspect in industries for that purpose mesh topology widely used. It referred peer-to-peer network. Multi hope network is the media to send the packets to destination.

Cluster Tree Topology - Leaf node device along with the coordinators creates cluster tree network. Coordinators are responsible for initiate the network and routers can be used for elongation of the network.

**3. HARDWARE DESCRIPTION**

Block diagram of hardware system is shown in fig-2 below. The system consist of three phase induction motor, voltage transformer, current sensors, digital signalcontroller, a digital temperature sensor, a desktop computer. To design the interface program java programming used and finally ZigBee module for wireless communication.

**4. SOFTWARE DETAILS**

The system software is used to build the Java Programming that works under the Windows Operating System. It has highly flexible programming structure. Motor parameters collected from the system transmitted through the ZigBee module to the computer over the RS232 protocol.

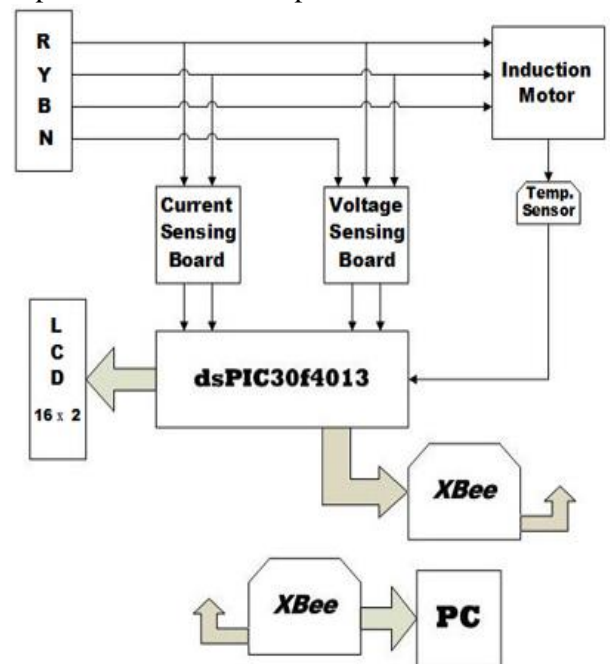

**Fig-2: Block diagram**

**5. CONCLUSION**

A brief review of the monitoring of various IM Parameters such as current, voltage, power and temperature can be achieved by using ZigBee technology. The proposed future work can be designed and implemented in the Electrical Engineering Department of DES's COET, Dhamangaon (Rly.).

**ACKNOWLEDGEMENT**

We take this opportunity to express our gratitude and indebtedness to our guide Ms. A. B. Nagdewate, Assistant Professor, Electrical (E & P) Engineering department, who has been constant source of guidance and inspiration in preparing this paper.

**REFERENCES**

[1]. Baran L., "A PLC based monitoring and control of power factor of a three phase induction

- motors,” MSc Thesis, Gazi University, Institute of Science and Technology, Ankara, 2009.
- [2]. Bayındır, R., Demirbaş, Ş., Irmak, E., Bekiroğlu, E., “Design and implementation of microcontroller based starting and protection relay for induction motors,” Journal of Polytechnic, 2007, pp.1-2.
- [3]. Bektaş, A., Çolak, İ., Bayındır, R., “A PLC based application for induction motor protection,” Journal of Polytechnic, vol.10, no. 2, 2007, pp.17.
- [4]. Chengbo YU, Yanfei LIU, Cheng WANG, “Research on ZigBee Wireless Sensors Network Based on ModBus Protocol,” Wireless Sensor Network, 2009, pp.1-60.
- [5]. Daniel AlexandruVişan, IoanLiță, Mariana Jurian and Ion BogdanCioc, “Wireless Measurement System Based on ZigBee Transmission Technology,” IEEE Transactions on 33rd Int. Spring Seminar on Electronics Technology, 2010.
- [6]. RamazanBayindir, Ibrahim Sefa, İlhamiColak, and AskinBektas “Fault Detection and Protection of Induction Motors Using Sensors,” IEEE transactions on energy conversion, vol. 23, no. 3, september 2008.
- [7]. R. R. Patil, T. N. Date, B. E. Kushare., “ZigBee Based Parameters Monitoring System for Induction motor,” Department of Electrical Engineering, K. K. Wagh Institute of Engineering Education and Research, Amrut-Dham, Panchavati, Nashik-422003, India.
- [8]. Siddique, A., Yadava, G. S., Singh, B. A., “Review of stator fault monitoring techniques of induction motors,” IEEE Transactions on Energy Conversion, vol.20, no.1, pp.106-114.
- [9]. VongsagonBoonsawat, JuraratEkchamanonta, KulwadeeBumrungkhet, and SomsakKittipiyakul, “XBee Wireless Sensor Networks for Temperature Monitoring,” Industrial Applications Conference, Sept 2007, pp.661-667.
- [10]. Zhang P., Du Y., Habetler TG, Lu B., “A Survey of Condition Monitoring and Protection Methods for Medium-Voltage Induction Motors,” IEEE Transactions On Industry Applications, vol.47, no.1, 2011, pp.34-45.
- [11]. Zhu XQ., Wang JM., “The research and implementation of ZigBee protocol network,” Journal of Electronic Technology, 2006, pp.129-132.