



Sensotronic Braking System: A Review

(The New Era of Braking System)

Mr. Mohammad Zeeshan^{#1}, Mr. Abhishek B. Lakade^{#2}, Mr. Nitin More^{#3},

#1,2 T.E Mechanical (Pursing), #3 Asst. Professor, SKN Sinhgad Institute of Technology & Science, Pune, India

#1 *master.zeeshan@gmail.com*

Abstract- Sensotronic Brake Control, is an appellation given by Mercedes to an innovative electrically controlled brake system which operates more precisely than a conventional hydraulic braking system. Within no time you press the brake pedal and the sensor identifies situation in hand, the microcontroller makes an correct calculation of brake force required and distributes it between the wheels as per the current scenario. This system is regarded as another important milestone to enhance driving safety. Also, the system offers features to reduce the driver's workload with additional features like Traffic Jam Assist, Soft Stop function, etc. SBC transforms the conventional hydraulic brake into a more powerful mechatronic system in which, a large number of mechanical components are only replaced by electronics which has simplified braking for driver and opened the new page for future and scope for brake-by-wire systems like never before. Despite being removed from practical use from most of the vehicles of Mercedes-Benz, the Sensotronic Braking System hasn't lost its significance.

Index Terms—Sensotronic Brake Control System, SBC, Working of SBC, Add-ons of SBC, Advantages of SBC, Faults or Problems in SBC, Future of SBC.

1. Introduction

It is evident from a myriad of studies by many experts that many drivers press the brake pedal slowly, just to ensure smooth and safe riding. Even when the emergency situation arises, almost all drivers tend to press the brake pedal partially for the first few milliseconds until their brain has time to analyze the situation and then the brake pedal is pressed firmly. This delay might look meager or the case may seem trivial, but this several times becomes the reason for an accident [3]. There are many other factors that cause the delay in vehicle's response time to the braking situation. Thus, Mercedes-Benz is trying to reduce or eliminate these possibilities with their new brake systems. They call it Sensotronic Brake Control (also known as SBC) System [6]. Sensotronic Brake Control is an electro-hydraulic brake system which was developed by Daimler and Bosch. The SBC system was introduced on the R230 SL-class vehicles, which went on sale in Europe in October 2001 [7].

1. Development and Working of Sensotronic Brake System

Although the working and development of a sensotronic brake system may seem to be a bit confounding from the below figure 1, since it is adaptation of mechatronics- a terms gaining its importance in automobile industry now a days, which brings together two different disciplines which in many cases were thought can never be fused together, namely mechanics and electronics [26]. The gist can be enumerated as shown below to makes things less complicated.

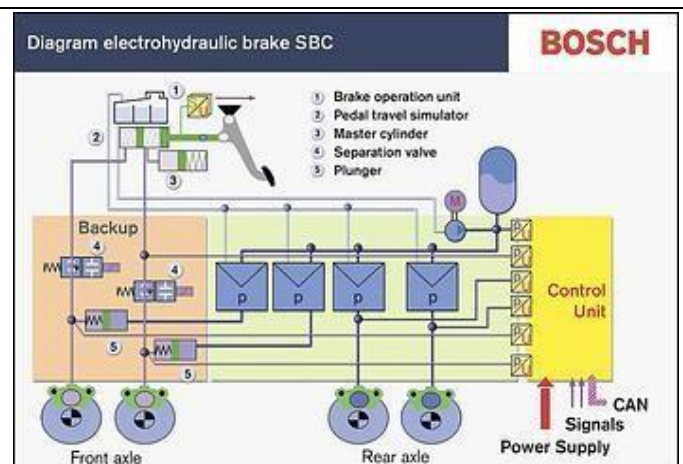

Figure1. Schematic Diagram for Working of SBC System

2.1 Brake pedal: Electronics Instead of a Vacuum

In the Mercedes-Benz Sensotronic Brake Control, a large number of mechanical components are simply replaced by electronics. The pressure inside the master brake cylinder in addition to the speed with which the brake pedal is operated is recorded and this data is passed to the SBC computer in the form of electric impulses by sensor gauges. In other words: during braking, the actuation unit is completely disengaged from the rest of the system and serves the sole purpose of recording any given brake command [3].

Only in the event of a major responsibility or power failure does SBC automatically use the services of the tandem master cylinder and instantly establishes a direct hydraulic link between the brake pedal and the front wheel brakes in order to decelerate the car safely [4].

2.2 Control unit: Pressure Modulators for Each Wheel

The control unit is the cardinal part of SBC. It is usually situated under the bonnet of the vehicle. This is where the

interaction of mechanics and electronics provide its greater benefits. The microcomputer, software, sensors, valves and electric pump all work together and allow total dynamic brake management [16].

In addition to the data relating to the brake pedal actuation, the SBC computer receives the sensor signals from the other electronic assistance systems. For example, the anti-lock braking system (ABS) provides information about wheel speed, turning rate and transverse acceleration sensors, etc. The transmission control unit finally uses the data highway to communicate the current driving range. The result of these complex and recondite calculations gives the brake command, which ensures optimum deceleration and stable driving as per the current scenario of the vehicle [24]. The SBC calculates brake force separately for each wheel and then the braking

action is executed accordingly as shown in figure 2, which tends to prove the efficient braking by SBC over predictable braking system.

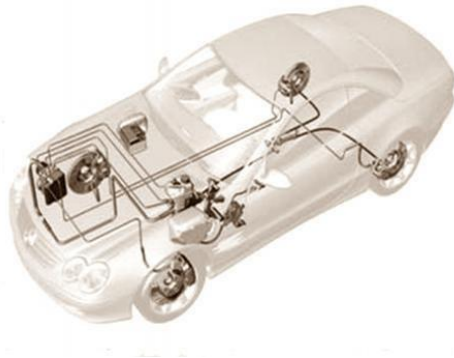

Figure 2. Braking action of SBC on all wheels

2.3 Emergency braking

The performance of SBC include the precise monitoring of driver and vehicle behavior using various sensors. Thus, Mercedes-Benz is trying to move into new dimensions of driving safety. Emergency Brake is the epitome of this feature.

SBC already recognises the driver's rapid movement from the accelerator onto the brake pedal as a clue to an imminent emergency stop and responds automatically. As a result of this, the stopping distance of a SBC equipped car from a speed of 120km/hr is cut by around three percent compared to a car featuring conventional braking technology as shown in figure 3 [5].



Figure 3. Comparison between Stopping by SBC and Conventional Braking System

2.4. Driving stability

In other critical situations – for example, when there is a risk of swerving. Under such conditions, the system interacts with the Electronic Stability Program (ESP) which keeps the vehicle safely on course through precise braking impulses at all wheels and/or by reducing engine speed, offering the benefits of greater dynamics and precision. ESP is able to stabilize early and comfortably a vehicle which is about to break away [14]. In this way, SBC is able to maintain

driving stability even during unfortunate conditions of swerve, reducing its effect with the help of ESP.

3. SBC add-on functions: Support systems to reduce driver strain

Despite the functions of a typical SBC which it already provides, the Mercedes-Benz has installed other additional functions which tend to reduce the driver strain as much as possible, due to its electronic brake [14]. The popular ones are mentioned below.

3.1 SBC Traffic Assist

In stop-and-go traffic the vehicle brakes automatically, when the foot is lifted off the accelerator pedal (“Traffic Jam Assist”). It can be engaged under 10 MPH. It remains active under 40 MPH. Driver can also activate it on downhill slopes as per his convenience, so the car won't speed over the set limit [15]. Hence, SBC's traffic assist feature makes things a lot easier whilst dealing with traffic signals or traffic jams in densely populated cities.

3.2. SBC Soft Stop

SBC gently brakes to a stop below 6 km/h by briefly reducing the brake pressure, soft stop reduces the jolt which occurs when braking immediately upon reaching a standstill, which often irks the driver [19]. Thus, this soft stop function increases the comfort level of the vehicle by circumventing this problem often faced by many.

3.3. SBC Hold

A “drive-away assistant” prevents the vehicle from rolling backwards or forward when starting on a hill or steep incline. A stiff push onto the brake pedal, and the car remains stopped, even when taking the foot off the brake pedal, until the driver accelerates and the vehicle begins to roll. Mercedes drivers usually tend to enjoy this feature. It was first introduced in the spring of 2003 in the 04 E-class Estate and later on in the 2004 SLs [12]. Figure 4. must have given you the gist of the Drive-away assistance at a glance.



Figure 4. Drive-away Assistance at hills or inclinations

A “drive-away assistant” prevents the vehicle from rolling backwards or forward when starting on a hill or steep incline. A firm push onto the brake pedal, and the car remains stopped, even when taking the foot off the brake pedal, until the driver accelerates and the vehicle begins to roll. Mercedes drivers usually tend to enjoy this feature. It was first introduced in the spring of 2003 in the 04 E-class Estate and later on in the 2004 SLs [12]. The figure 4. must have given you the basic idea about the Drive-away assistance at a glance.

3.4. Dry Brake

And finally there is the dry brake function. It is always activated when the windshield wipers run. The system then identifies, that it rains and, with short brake pulses unnoticed by the driver, keeps the brake discs always dry and fully functional [5].

4. Advantages of SBC

Thus, with all the add-ons and features offered by SBC, it becomes easy to enumerate the advantages that SBC gives over the conventional braking system [6].

1. Improving metering of necessary brake pressure, and each wheel can be precisely controlled.
2. Reduction in stopping distance in particular during an emergency stop.
3. Increase in active vehicle dynamics safety as the vehicle dynamics control system ABS and ESP can be used in an optimized manner.
4. Leads to more timely and more comfortable stabilization of the vehicle during ESP control.
5. Take care of even wear on the brake linings and better response characteristics of the brake due to optimal brake force distribution between the front and rear axle.
6. Use of the brake force reserve at the rear axle due to growing the brake force share in the partial braking range and when braking from a low speed.
7. Consequences in more stable braking performance with optimal deceleration values when cornering as a result of the braking forces being shifted to the outer wheels.
8. No reaction (vibration) on the brake pedal during ABS control intervention functions.

5. Problems Faced by SBC

Mercedes decided to discontinue its Sensotronic Brake Control system follow a number of troubles with the brake-by-wire technology. Failures related to the system have lead to two significant recalls involving over 2 million vehicles [20]. There have been no accidents as a result of these defects, but Mercedes reportedly decided to quit using the system in an effort to improve its reputation for build quality [22].

Problems with SBC comprise the system in advance switching to the hydraulic emergency backup due to a problem with wiring. According to Mercedes, vibration from the Sensotronic hydraulic braking unit could affect the electrical contacts within the connector plug. The emergency mode still provides "safe" braking, but not what the driver is accustomed to [18].

Unfortunately, although the intention was good, the execution was not up to the expectations. The main cause for its deterioration was the failure in the wiring system. We cannot rule the possibilities of computer and pump failure. In comparison to its advantages, though the disadvantages may not seem to cause a concern, but still some features like high maintenance, costly electronic parts to replace and noise from the SBC hydraulic motor add to people's concern regarding its future implementation [18]. This Mercedes braking system has led to an advent of an astonishing unprecedented era.

6. Circumventing the Problems faced by SBC

On behalf of our personal capacity, we think that the problems faced by SBC can be avoided. Use of Fuzzy Logic can help in attaining that. Fuzzy logic is a form of many-valued logic that deals with logic that is fairly accurate rather than fixed and exact [8]. Fuzzy Logic Controller (FLC) based on fuzzy logic provides a means of converting linguistic control strategies into automatic control system. The dynamic braking resistor is a very effective device for stability control of any car. FLC plays a very important role in improving this brake resistor control unit by using Fuzzy Logic toolbox in MATLAB and PID controller [8]. This technology if used in the microcomputer will definitely increase its advancement in the future as a result completely nullifying the problems arising due to malfunctioning of the system [23].

It is true that to replace the vacuum braking system, this electromechanical braking system was brought in use by Mercedes by superseding the hydraulic parts by electronic parts. Focusing on either electronics or mechanics is not the ultimate aim in achieving growth, but designing a braking system with can economically satisfy all the functions of a braking system. Thus we think that the main challenge for the future of automobile companies is to find the right trade-off between cost and performance and try to work with a definite methodology.

7. Future Scope

The arrival of electronics in brake technology opens up new and promising opportunities to Mercedes engineers – and not only in the disciplines of safety and console. By means of SBC they have also moved a considerable way closer to the realization of their long-term objective, namely to be able to automatically guide the cars of the future along the roads with the aid of video cameras, proximity radar and advanced telematics. For such autonomous vehicle guidance, the experts need a computer-controlled brake system which automatically acts on the instructions of an electronic autopilot and stops the car safely [1]. Also, Mercedes engineers are exploring new and promising avenues beyond just comfort and safety.

8. Conclusion

In simple words, we can conclude that the Sensotronic Braking Technology is system comprising of mechanics and electronics which provides its benefits to a greater extent over the conventional braking system. Considering the disadvantages it is irrational to conclude that Mercedes will entirely scrap SBC system. It will surely continue to develop and improve braking system with less prone conditions to malfunctioning. The fact cannot be neglected that the additional advantages of Sensotronic braking system provide uncompromising quality, stability and longevity. Combination of manage ride and handling with driving safety provided by the braking system in a sustainable and calculable way differentiates it with other braking system in a lucrative way. Many times the coding part of the microcomputer was changed. With respect to these changes and studying other brake systems, it is easy to conclude that the Integrated Brake control system is being undertaken everywhere which enhances performances and enables

cornucopia of features and future scope over the conventional braking system.

References

- [1] Konrad Reif, "Automotive Mechatronics: Automotive, Networking, Driving Stability Systems, Electronics", Bosch Professional Automotive Information.
- [2] Isidoros Krastyo Morpheus, "Sensotronic Brake Control", Until Publishing, Year 2012.
- [3] Tejas Parge and Siddharth Kshirsagar, "Sensotronic Braking Systems", International Journal of Engineering Technology management and Applied Sciences, Vol.2 Issue 3, August 2014.
- [4] L.Nagbhushan Reddy Technical paper, "Sensotronic Brake Control System", May 2010.
- [5] Zeng and Zong, "Sensotronic Braking Systems", SAE Technical Paper, January 2013.
- [6] Mercedes Benz Technical Publication, Sensotronic Brake Control System.
- [7] Mercedes Benz Technical and Maintenance, official website, Sensotronic Brake Control System.
- [8] Bernhard Kant, "Brakes, Brake Control and Driver Assistance Systems", Bosch Professional Automotive Information pp 154-157 19 July 2014.
- [9] Christian Corondo Mondragon, "The case of Automotive by-wire Systems", Science Direct, Volume 118, Issue 2, April 2009.
- [10] Georg Kacher, "Mercedes-Benz SL-Class", Automobile, 1 November 2001.
- [11] Mike Hanlon, "Mercedes Benz GST", Gizmag, 4 June 2004
- [12] Identifix Inc., "2003 Mercedes SBC brake system", Modern Tire Dealer, 29 August 2011
- [13] Zhou Zhiguang and Zhang Guixiang, "Research of Variable Pavement Vehicle SBC Based on Adaptive RBF Neural Network Sliding Mode Control", IEEE Conference, Pages 536-540, 10 November 2009.
- [14] AutoLand Science Tech Co. Ltd. "Mercedes-Benz: SBC (Sensotronic Brake Control) Activation", Year 2009.
- [15] Peter H., "Traffic Sign Assist", The Mercedes-Benz Page, 20 October 2015.
- [16] Peter H., "Sensotronic Brake System", The Mercedes-Benz Page, 16 December 2009.
- [17] Peter H., "Mercedes W199 SLR 2004 – 2009", The Mercedes-Benz Page, 17 March 2010.
- [18] Atlantic Motor Car Center, "Mercedes SBC faults", 29 March 2013.
- [19] Honest John, "Mercedes-Benz E-Class brakes stopping short", The Telegraph, 22 December 2013.
- [20] Jens Miener, "Mercedes cancels by-wire brake system: Decision A blow to technology's future", The Auto News, 15 December 2005.
- [21] Jeff Bartlett, "2001 Frankfurt Motor Show", The Truck Trend, 11 June 2015.
- [22] Lindsay Chappell, "By-wire age is coming: what's missing is trust", Automotive News, 2 December 2013.
- [23] Hans-Peter Schoner, "Automotive Mechatronics", Science Direct, Research Article, Control Engineering Practice, Vol 12, Issue 11, Pages 1343-1351, November 2004.
- [24] Daimler Chrysler, "Sensotronic Brake Control: Taking braking to the next generation", AutoSpeed, 5 Dec 2000.
- [25] Anton T and Robert Bosch, "Evolution of Electronic Control System for improving Vehicle Dynamic Behavior", *ResearchGate*, June 2013.
- [26] Article "Advances in Automobile Industry- Sensotronic Braking System", *ManchesterBlogspot*, 6 March 2011.