



Modification and Fabrication of Three Axes Modern Trailer

Mr. Wani Amit P, Mr. Deore Devendra M.
Mr. Chaudhari Kundan Y., Mr. Badgujar Jayesh A.
Student B. E. (Final Year Mechanical Engineering)

SKN Sinhgad Institute of Technology & Science
Lonavala, Maharashtra, India.
waniamit121@gmail.com

Prof. Pawan R. Ingole
Department of Mechanical Engineering
SKN Sinhgad Institute of Technology and Sciences,
Lonavala, Maharashtra, India.
pawaningole5@gmail.com

Abstract—“Modification and Fabrication of Three tomahawks Modern Trailer” has been brought about by watching the trouble in emptying the materials. The study in such manner in a few car carpports, uncovered the actualities that for the most part some troublesome strategies were received in emptying the materials from the trailer. Presently the undertaking has for the most part focused on this trouble, and subsequently a suitable course of action has been planned. Such that the vehicles can be emptied from the trailer in three tomahawks without utilization of any effect power. By squeezing the Direction control valve, compacted air is goes to the pneumatic barrel through valve. The ram of the pneumatic barrel goes about as a lifting the trailer lodge. The car motor drive is coupled to the compressor motor, with the goal that it stores the compacted air when the vehicle running. This compacted air is utilized to enact the pneumatic chamber, when the valve is initiated.

Index Terms— Fabrication, Impact power, Pneumatic

I. INTRODUCTION

A dumper is a vital part of any development work and henceforth its part is imperative for finish of any constructional site. One of the issues connected with dumper is the time and vitality required for setting the enormous dumper in the best possible bearing. To beat this issue the need of the venture work emerge which is around 3 way dropping dumper which can dump the material in any heading aside from the rental one without moving the truck. A three-way tipper can empty materials in each of the three bearings. The car motor drive is coupled to the compressor, with the goal that it stores the compacted air when the vehicle is running. To control the development of tipper on both sides, two more pneumatic barrels are required. Likewise we require exceptional sorts of pivot joints for this situation. This tipper instrument can empty the products in three headings. This tipper instrument for the most part identifies with ball attachment joint for emptying the material in left side or in right side bearing and utilization of water driven jack in posterior. This paper speaks to the upsides of three tomahawks trailer and its proficiency of utilization over the customary trailer.

A. Problem Statement

It is exceptionally hard to empty the materials in right side or left half of the trailer. By squeezing the course control valve, the packed air goes to the pneumatic barrel through valve; the ram of the pneumatic chamber get initiated and lift the trailer lodge. The car motor drive is coupled to the compressor motor,

with the goal that it stores the compacted air when the vehicle is running. This compacted air is utilized to initiate the pneumatic barrel, when the valve is opened.

B. Selection of Pneumatics

Automation is comprehensively characterized as the substitution of manual exertion by mechanical force. Pneumatic is an alluring medium for minimal effort automation especially for successive or dull operations. The pneumatic framework is typically financial and straightforward, with less support. It can likewise have remarkable favorable circumstances as far as security.

II. LITERATURE SURVEY

McLellan et al [1907] of Glasgow concentrated on water power, in which record demonstrates to one of the main pressure driven dump bodies was the Robertson Steam Wagon with a water powered lift that got power from the trucks motor or a free steam motor was created another early water driven dump body in that was force driven by steam. [1] Robert Boyle et al [1962]. The compressibility of the air was initially researched by Robert Boyle in and that found that the result of weight and volume of a specific amount of gas. The standard composed as $PV = C$. [2] Ganesh Shinde et al concentrated on the “Cutting edge 3 Ways observing so as to drop dumper” which has been brought about the trouble in emptying the materials. The study in this respects in a few vehicles carpports, uncovered the certainties that for the most part some troublesome strategies were received in emptying the materials

from the trailer. [3] Heinz-Herbert Cohrs et al refers to that before the primary dump trucks showed up, exhumed materials were being uprooted and pulled by trains and trolleys known as box tip wagons, dump bodies, and scoop tippers. The pup trailer, not at all like the exchange, has its own particular water driven slam and is equipped for self-emptying. [4] Saint John et al [1920] the landfill truck was initially imagined in Saint John, New Brunswick when Robert T. Mawhinney appended a dump box to a flatbed truck. The lifting gadget was connected to a link that nourished over pulley mounted on a pole behind the taxicab. The link was associated with the lower front end of the wooden dump box which was appended by a turn at the back of the truck outline. The administrator turned a wrench to raise and lower the crate. Water driven framework has subsequent to supplanted the wrench handle, however the fundamental, idea has stayed unaltered. [5]

Crawler et al [1920] Tractor-Trailer, crawler tractors pulling overwhelming dump trailers mounted on wheels or tracks. Some of the time crawlers would pull two to five appended trailers. The principal renditions were mounted on tracks; nonetheless, when speed confinements represented an issue, the wagons were mounted on wheels to enhance speed. Makers of such trailers and haulers included Euclid, James Hagy, LaPlant-Choate, Rex-Watson, and Streich and Western. [6] Euclid et al [1936] was a pioneer in the improvement of dump trucks. George Armington Jr., child of author George Armington, was made two critical commitments to the universe of dump trucks. In 1934 the organization presented its 10/11-ton dump truck called the "Track Truck" was the primary back dump truck. This was caught up in with the organization's 15-ton Model IFD truck that included a diesel motor, present day drive line, planetary last drives, leaf-spring suspension, and pneumatic tires. Another noticeable improvement was the dispatch of Euclid's wheel tractor base dump wagon blend. Along, with Le Tourneau's Tournapull, the Euclid base dump was a noteworthy headway in earthmoving. [7]The material emptying procedure is done in three tomahawks with the assistance of locking course of action and pneumatic framework. In this cutting edge three tomahawks pneumatic trailer framework, the air circuit assumes an imperative part. It A double acting cylinder connects both the universal joints in the frame by using knee joint. Hoses are connected to the double acting pneumatic cylinder. Another side of the hose is attached to the directional control valve, for locking the system.

III. WORKING

Major parts of pneumatic three axes modern tipper are:

- A. Air compressor
- B. Direction control valve
- C. Cylinder
- D. Connecting hoses
- E. Flow control valve
- F. Wheel arrangement
- G. Vehicle model frame

Fig.1 demonstrates the working standard of pneumatic barrel utilized as a part of current trailer. For the working of

is important to comprehend the development and working rule of the air circuit.

To start with we can begin with the packing of the air; the climatic air which is at ordinary weight is taken by the responding compressor and changed over into higher or lower weight contingent upon the prerequisite. The packed air is setting off to the pneumatic chamber through the heading.

The bearing control valve is utilized to control the stream course of the pneumatic barrel in both the heading. The pneumatic chamber is mounted on the case. Another two pneumatic barrels are joined to the undercarriage of trolley for locking the movement on stand outside. [8]

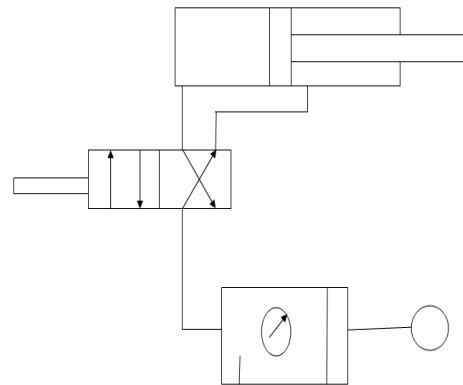

Fig.1 Circuit Diagram of 4/2 Direction Control Valve.

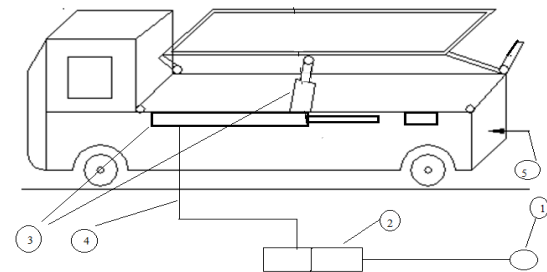

Fig.2 Construction of Trolley

trailer, we are utilizing pneumatic air as a source. The 4/2 bearing control valve is utilized to control the course of the air. At the point when the bay port is opened, the air is pumped from the sump by utilizing compressor. The trailer is presently pushed upward in the Y-hub heading. When outlet port is enacted, the trailer is pushed down in Y-course. The locking arrangement of the trailer is incited for trailer activity in Z-pivot. At the point when the channel port is opened, the trailer is presently pushed upward in the Z-hub heading and the outlet port is actuated, pushing the trailer in Z-hub. By opening the delta port, the trailer is currently pushed upward in the X-hub heading.

IV. ADVANTAGES

- A. Time saving.
- B. Less space required for vehicle to unload.
- C. Less fuel consumption.

- D. Reduces workload for operator.
- E. Very less maintenance is required.

V. LIMITATIONS

- A. Separate air tank or compressor is required.
- B. Stability is less.
- C. Increased complexity.
- D. Initial cost is high.

VI. APPLICATION AREAS

- A. Main application of any trailer is to dump the material in required direction, but by using this modern three way trailer, we can dump the material in three axial directions.
- B. It can be used on mass production sites, where demand of material is more.
- C. It can be used for agricultural purposes.
- D. It can be economically used in large construction sites.
- E. This modern three way trailer is very useful where time is the important factor for completion of work.
- F. It can be efficiently operated on the sites where the working space for dumping of material is very congested.

VII. FUTURE SCOPE

As the world is progressing at faster rate we need more efficiently working equipments and vehicles. The three axes lifting modern hydraulic trailer can be used more efficiently two ways or one way trailer.

The three axes trailer can be modified further more on following basis:-

- A. Dual stage cylinders can be used.
- B. Oil pump can be used instead of powered cylinder.
- C. Capacity can be increased as per the requirement.
- D. Wheel steering system can be adopted for avoiding the lifting of vehicle along with trailer.

VIII. CONCLUSION

This work has given us a great chance to utilize the subject information of Hydraulics and Pneumatics to minimize human exertion and work effectively in less accessible space pick up. Further adjustments will put this work in the fundamental group of utilization. This idea spares time and vitality which prompts productive working. The three tomahawks advanced trailer furnishes us with more odds of working under basic and congested condition on locales of development and mines, where accessible space is less to work a trailer. The locking framework empowers us to improve the level of opportunity for the

development of trailer. The framework is mechanized and less human endeavors are requested.

REFERENCES

- [1] International Journal of Applied Engineering Research ISSN 0973-4562 Volume 10, Number 11 (2015) © Research India Publications.
<http://www.ripublication.com> 10578
- [2] Automotive Industry Standard. "AIS-93: Code of Practice for construction and approval of truck cabs, truck bodies and trailers."
- [3] Ganesh Shinde, Prachi Taweale, and Laukik Raut, Design and Development of 3-Way Dropping Dumper, International Journal of Emerging Technology and Advanced Engineering, 4(9), 2014, 2250-2459.
- [4] Automotive Industry Standard. "AIS-053: Automotive Vehicles-Types - Terminology."
- [5] S. Prabhu, "Stress analysis on truck chassis using finite element analysis." International Journal of mechanical Engineers (India), Volume 1, issue 1, pages 55-61, January- June 2008.
- [6] ABS Guide for Certification of FRP Hydrocarbon Production Piping System, American Bureau of Shipping, 2005.
- [7] V. Bhasker, R. Babu and V. Shekhar, "Process integration and automation solutions for rapid designing of automotive frame structures using altairhyperworks." In Hyperworks Technology Conference. Altair Hyper works, 2008.
- [8] C. Karaoglu and N. S. Kuralay, "Stress analysis of a truck chassis with riveted joints." Finite element in analysis and design, Elsevier, pages 1115-1130, 2002.
- [9] T. H. Fui and R. Abd. Rahman, "Static and dynamics structural analysis of a 4.5 ton truck chassis." Jurnal Mekanikal, No. 24, pages 56-67, 2007.
- [10] Dubey and V. Dwivedi, "Vehicle chassis analysis: load cases and boundary conditions for stress analysis." In 11th National Conference on Machines and Mechanisms. IIT, Delhi, India, December 2003.
- [11] S. Tiwari, "Evolution of empirical relationship between high level design parameters with performance criteria of a ladder type chassis frame." Master's thesis, Institute of Technology, Nirma University, May 2007.
- [12] A.M. Harte, J.F. McNamara, I.D. Roddy, "A multilevel approach to the optimization of a composite light rail vehicle body shell.", Composite Structures, Elsevier, pages 447-453, 2004.
- [13] The Indian Road Congress, New Delhi. "IsRC 3: 1083, Dimensions and weights of road design vehicle", first revision edition.
- [14] O. Kurdi, R. Abd. Rahman and M. N. Tamin. "Stress analysis of heavy duty truck chassis using finite element method." Faculty of Mechanical Engineering, University Technology Malaysia.
- [15] "The Central Motor Vehicles Rules, 1989." Bureau of Indian Standards, New Delhi. "IS 2062:1999, Steel for

general structural purposes-specification”, fifth revision edition.