



## Analysis and Manufacturing of Voltage Regulator Casing Used In Military Tanks

Mr. Sachin D. Shinde, Ms. Prajka P. Kanase,  
Ms. Janice B. Gonsalves  
Student B. E. (Final Year)  
SKN Sinhgad Institute of Technology  
Lonavala, Maharashtra, India.  
[sdshinde0123@gmail.com](mailto:sdshinde0123@gmail.com)

Prof. Pawan R. Ingole  
Mechanical Engineering Department  
SKN Sinhgad Institute of Technology  
Lonavala, Maharashtra, India.  
[pawaningole5@gmail.com](mailto:pawaningole5@gmail.com)

**Abstract**—Voltage controller is the most vital part of any electrical framework utilized as a part of the car. These are accessible in extensive variety of use. A defensive control box i.e. packaging is unveiled for giving security to the voltage controller in the military tanks. Material utilized is the aluminum as it is the world's most rich metal and its inborn and flexible properties of gentility, quality to weight proportion, consumption resistance, electrical and warm conductivity. This paper speaks to the examination of voltage controller packaging done in ANSYS and specifying of its assembling process

**Index Terms**— Thermal Conductivity, Analysis, Simulation.

### I. INTRODUCTION

Aluminum assumes a noteworthy part in the present day world as a result of its natural and adaptable properties of daintiness, quality to weight proportion, consumption resistance, electrical and warm conductivity, no poisonous quality and so on. As castings, either as like car and diesel cylinders, car timing gear, gear boxes, cast or warmth treated, Aluminum is bit by bit supplanting Gunmetal, bronze, stainless steel and numerous dark iron and flexible iron castings. Motor parts wrench cases, grip lodging, pump bodies, section, arms and holders for various businesses, segments, fittings for synthetic and marine uses, railroads, stockpiling tanks, flywheel lodging and propellers, craftsmanship metal work, forming flagons, center drying plates and example castings, rotor of roof fans and numerous different segments in various fields are made of Al-castings[1]. The reason for each voltage controller is to change over given air conditioning or dc voltage into particular yield of dc voltage.

#### A. Problem Statement

Analysis and manufacturing of casing of voltage regulators used in military tanks which are manufactured by using Aluminium metal and its alloys. Analysis is being carried out in ANSYS and results are discussed.

#### B. Objectives

- To provide a survey of the Aluminium alloys available to the user
- To give an insight into the choice of Aluminium for a proposed application.

Aluminium is the backbone of the aerospace industry, is used to assist with cooking and packaging, assist in the manufacturing of high grade steel and is the base for a versatile paint It is also soft, hard, easy to weld, difficult to weld, and a host of other seemingly conflicting characteristics [2].

#### C. Scope

A model was developed by Alcoa Inc. to provide a quantitative understanding of historic and today's (year 1950 through year 2003) worldwide Aluminium mass flows and systems losses.

### II. PROPERTIES OF ALUMINIUM ALLOYS

#### A. xxx - Pure Al

The 1xxx series represents the commercially pure Aluminium, ranging from the baseline 1100 (99.00% min. Al) to relatively purer 1050/1350 (99.50% min. Al) and 1175 (99.75 % min. Al) [3].

#### B. 2xxx - Al-Cu Alloys

This alloy is heat treatable. It has high strength, at room & elevated temperatures. These alloys are used in Aircraft and transportation applications. The typical ultimate tensile strength range is from 27-62 ksi.

The 2xxx series are heat-treatable, and possess in individual alloys good combinations of high strength (especially at elevated temperatures), toughness, and in specific cases, weld ability [4].

#### C. 3xxx - Al-Mn Alloys

As the alloy has high formability, corrosion resistance, and join ability medium strength it can be used in heat transfer, packaging, roofing-siding applications. Its representative alloys: 3003, 3004, 3005 Typical ultimate tensile strength range: 16-41 ksi. The 3xxx series are strain-hard enable, have excellent corrosion resistance, and are readily welded, brazed

and soldered. Alloy 3003 is widely used in cooking utensils [5].

#### D. 4xxx - Al-Si Alloys:

These are heat treatable alloys with good flow characteristics and medium strength. These are used in manufacturing pistons and complex-shaped forgings. Its representative alloys: 4032 and filler alloy 4043. These have typical ultimate tensile strength in the range 25-55 ksi [6].

#### E. 5xxx - Al-Mg Alloys:

These alloys are strain hardenable and have excellent corrosion resistance, toughness, weld ability and moderate strength. These are used in building & construction of automotive, cryogenic and marine applications. Its representative alloys are 5052, 5083, 5754. Their typical ultimate tensile strength range is from 18-51 ksi [7].

### III. SELECTION CRITERION

Corrosion involves the movement of metal ions into the solution at active areas (anode), passing of electrons from the metal to acceptors at less active areas (cathode), an ionic current in the solution and an electric current in the metal. The cathodic process requires the presence of an electron acceptor such as oxygen or oxidizing agents or hydrogen ions. The use of chemical inhibitors has been limited because of the environmental regulations, and hence plant extracts have become important because they are environmentally acceptable, readily available and renewable source for a wide range of needed inhibitors. For instance, Henna leaves *Gossypium Higgutum*, Gum Arabic, *Phyllanthusamarus*, *ipomoea involucrate*, *Hibiscus Sabdoriffa*, *Adathoda vasica damisissa*, Brahmi, pipali leaves etc., have been studied as effective corrosion inhibitors for aluminium in alkaline medium [8]. Current engineering applications require materials that are stronger, lighter and less expensive. Metal matrix composites (MMCs) have been noted to offer such tailored property combinations required in a wide range of engineering applications. Some of these property combinations include: high specific strength, low coefficient thermal expansion and high thermal resistance, good damping capacities, superior wear resistance, high specific stiffness and satisfactory levels of corrosion resistance [9]. MMCs are fast replacing conventional metallic alloys in so many applications as their use have been extended from predominantly aerospace and automobile to defense, marine, MMCs etc. Hydrogen metal matrix composites are unique material fabricated by reinforcements of at least two types of ceramic particles into a tough metal matrix [11].

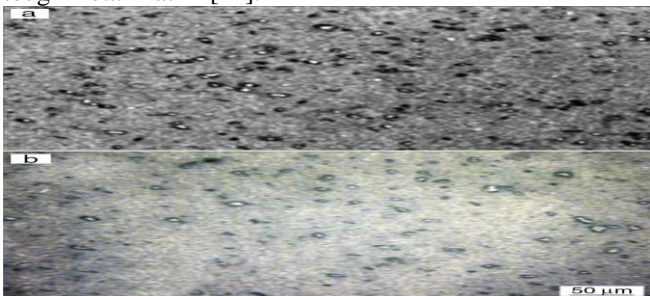

Fig.1 – Microstructure of surface hybrid composites

Aluminum composites are more alluring for utilizations of car, aviation and marine industry because of their high particular quality, consumption resistance and weld capacity. Rubbing mix welding is another strong state welding procedure created by The Welding Institute (TWI) for joining of aluminum amalgams and other metallic materials [10]. Uniform bead splash is another innovation to deliver uniform circular metal powders [12]. As of now the utilization of MMC's has expanded in different regions of science and innovation because of their uncommon physical and mechanical properties [13]. In miniaturized scale range powers identified with the surface of a body surpass powers identified with its volume. This implies the impact of surface strain is bigger than impacts brought about by attractive energy [14].

### IV. LITERATURE SURVEY

V.Suresh, R.Maguteeswaran, R.Sivasubramaniam, D.ShanmugaVadivel“Micro Tensile Behaviour of LM25 Aluminium Alloys by Stir Cast Method Compared with Finite Element Method” Total Deformation consists of minimum and maximum Young's modulus values. . The minimum equivalent elastic strain value is 3.7366e-5, the average equivalent elastic Strain value is 0.00016488 and maximum equivalent elastic strain value is 0.00039177. Structural value is 8.3285e-5 and the blue color in the diagram shows the Structural deformation in the Aluminium alloy LM-25.Following results are based on experiments.

TABLE I. LM25 PROPERTIES

Mechanical Prop	Sand Cast	Gravity Die Casting
Tensile Strength(n/mm <sup>2</sup> )	130-150	160-200
Elongation Percentage (%)	2-3	3-6
Brinell Hardness No.	55-65	55-65

Mr.Prashant Kumar Suragimath, Dr. G. K. Purohit “A Study on Mechanical Properties of Aluminium Alloy (LM6) Reinforced with SiC and Fly Ash” Microstructure Analysis: It is necessary to distribute particles uniformly throughout the casting during production of particulate composites. Tensile test is carried out at room temperature using universal testing machine. In this study it can be noted that the addition of SiC and Fly Ash partially proved the tensile strength of the composites.

TABLE II. LM6 PROPERTIES

Mechanical Prop	Sand Cast	Gravity Casting	Die
Tensile Strength(n/mm <sup>2</sup> )	160-190	160-220	
Elongation Percentage (%)	5-10	7-15	
Brinell Hardness No.	50-55	55-60	

'B. VijayaRamnatha, C. Elanchezhiana, M. Jaivignesha, S.Rajasha,C.Parswajinanb, A. Siddique Ahmed Ghiase. "Evaluation of mechanical properties of aluminium alloy-alumina – boroncarbide metal matrix composites." The ability of a material to withstand a static load can be determined by testing the material in tension or compression. The tensile test is done using universal testing machine and the specimens are cut as per the ASTM: B-557M standard. The results obtained for Sample 2 are Break load 6.47kN and Maximum displacement is 6.4mm.

### V. MODELLING AND ANALYSIS

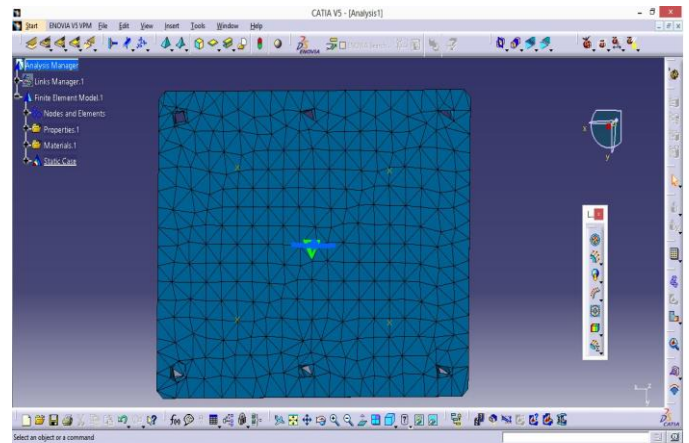
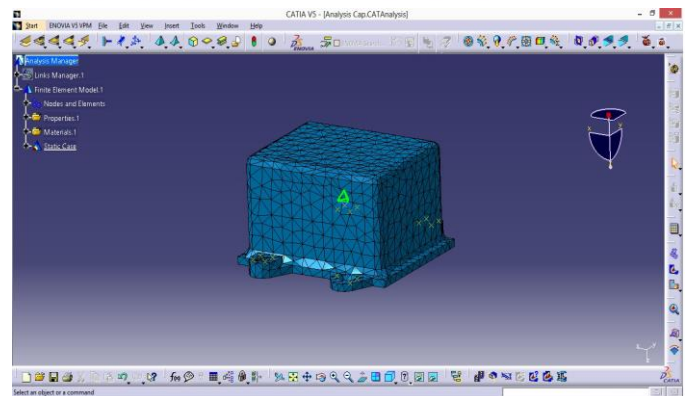
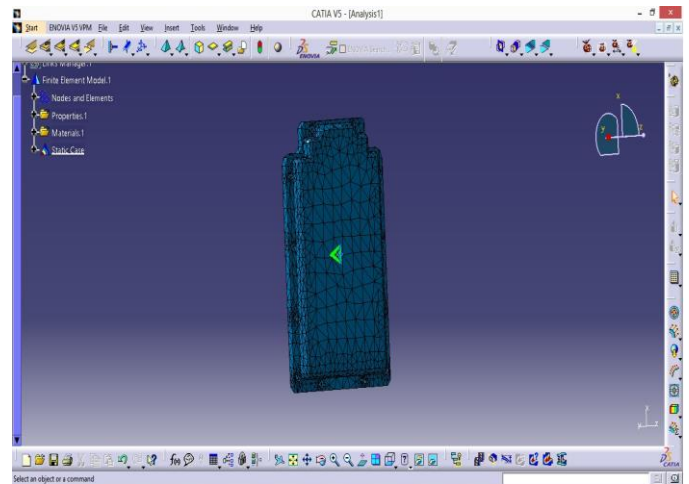
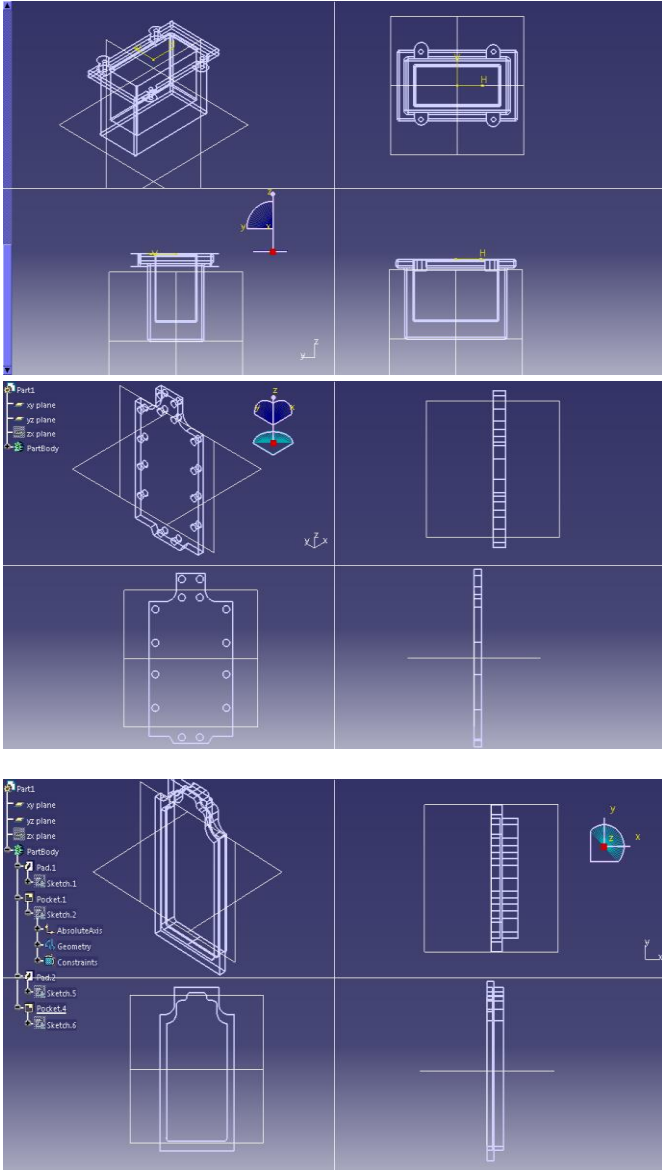

CATIA (Computer Aided Three-dimensional Interactive Application) is a Multi-platform CAD/CAM/CAE commercial software suite developed by the French company Dassault Systems. Written in the C++ programming language, CATIA is the cornerstone of the Dassault Systems software suite. According to the dimensions given by the company after measuring its sizes, we started the modelling of the casing. We first made the model on a rough basis and showed the design to the engineer after getting the approval to continue the design, we started the final design of the casing.

The analysis dig in blue is after the application of load. When the load is applied, the part will deform or will withstand.

will depend on the amount of load applied on it. First two parts when applied to load did not deform due to its base support. But the third part deformed due to side structure. The analysis shows that there will be deformation only if the load applied will exceed 100KN.

#### VI. CONCLUSION

Aluminum assumes a noteworthy part in the cutting edge world through its countless applications, due to its inborn and flexible properties of softness, quality to weight proportion, consumption resistance, electrical and warm conductivity, no danger, and so forth. A defensive control box i.e. packaging is unveiled for giving assurance to the voltage controller in the military tanks. This paper concentrates on the examination of voltage controller packaging utilized as a part of the military tanks by ANSYS, choice of metal for the packaging and its assembling process.

#### ACKNOWLEDGMENT

The authors would like to thank "Indesys Equipment's Pvt. Ltd." for all their support and guidance.

#### REFERENCES

- [1] A.Meyveci, I.Karacan, U.C.alig'ul'u, H.Durmus,, Pin-on-disc characterization of 2xxx and 6xxx aluminium alloys aged by precipitation age hardening. *Journal of Alloys and Compounds* 491, 278-283 (2010).
- [2] Ron Cobden, Alcan, Banbury Aluminium: Physical Properties, Characteristics and Alloys Basic Level Page no 1 Line No: 1-8.
- [3] The Aluminium Association, Inc. A Review of Aluminium Alloy Series, Their Principal Characteristics and Applications Page No.7
- [4] The Aluminium Association, Inc. A Review of Aluminium Alloy Series, Their Principal Characteristics and Applications Page No.8
- [5] The Aluminium Association, Inc. A Review of Aluminium Alloy Series, Their Principal Characteristics and Applications Page No.9
- [6] The Aluminium Association, Inc. A Review of Aluminium Alloy Series, Their Principal Characteristics and Applications Page No.10
- [7] The Aluminium Association, Inc. A Review of Aluminium Alloy Series, Their Principal Characteristics and Applications Page No.11-13.
- [8] A.Sirajunnisaa,b,\* , M.I.Fazal Mohamedb, A.Subramaniac, B.R.Venkatramand Green Approach To Corrosion Inhibition Of Aluminium By Senna Auriculata Leaves Extract In 1 N NaOH Solution page no: 58, 59
- [9] Michael Oluwatosin Bodunrina,b,\* , Kenneth Kanayo Alanemea,c, Lesley Heath Chownb Aluminium matrix hybrid composites: a review of reinforcement philosophies; mechanical, corrosion and tribological characteristics Page no: 2-3
- [10] T.S.Mahesh Babua, M.S.Aldrin Suginb and Dr.N.Muthukrishnanc, Investigation on the characteristics of Surface Quality on machining of Hybrid Metal Matrix Composites(Al-SiC-B4C), Page No.2
- [11] N Srujana, O Umadevi & G Venkateswarlu\* Influence of Tool Pin Profile on Microstructure and Mechanical Properties of Friction Stir Welded 6351 Aluminium Alloy. Page no: 1
- [12] Jun Luo,a,b, Fang Yanga, Songyi Zhonga, Lehua Qia,b,\* Modelling of uniform micron-sized metal particles production using harmonic mechanical excitation.
- [13] C.Dhavamaniam and T.Alwarsanyb, Optimization of Machining Parameters for Aluminium and Silicon Carbide Composite using Genetic Algorithm, Page No. 2.
- [14] Heiko Brüning, Marcel Teepe, Frank Vollertsen\*, Surface roughness and size effect in dendrite arm spacing at preforms of AISI 304 (1.4301) generated by laser rod end melting, Page No.2.

